

Cruise Report for PR1S and PR24

PR1S: A Hydrographic Section along 130-00'E

PR24: A Hydrographic Section from Mindanao SE to  
Indonesia

6N :A Hydrographic Section from Mindanao SE to Palau

28 April 1994

R/V KAIYO  
12 Feb. 1994 - 3 March 1994

# Contents

1. Highlight
  2. Summary of the observations and data files
  3. Cruise track, stations and sampling depths
  4. Preliminary results
  5. Parameters, Contribution Institutions, and Personnel
  6. Underway Measurement
  7. Sampling/measurements equipments
  8. CTD/Rosette hardware
  9. Moorings
  10. CTD/Rosette operation
  11. CTD data processing
  12. Sample water salinity measurements
  13. Dissolved Oxygen determination
  14. Nutrients measurements
  15. Plant Pigments measurements
  16. Drifters
  17. Distribution of atmospheric and oceanic CO<sub>2</sub>
  18. C-14 sample drawing
  19. Weather and sea condition
  20. Problems
  21. Report on CTD system performance
- Acknowledgements

## List of Tables

Table 2-1 KYZZZZ94.SUM

Table 4-1 The average and the standard deviation of the properties below 3000 dbar

Table 5-1 List of parameters measured, the sampling group(s) responsible for each, and the principal investigator(s) for each.

Table 5-2 Cruise participants

Table 6-1 Sampling equipments

Table 7-1 The differences between water depth estimated summing of CTD observation plus altimeter reading and uncorrected echosounding depth

Table 8-1 Summary of RTM and RPM data. Average (upper row) and Standard deviation (lower row)

Table 11-1 Definition of noise and the number of noise detected by this definition

Table 12-1 Summary of standardization

Table 12-2 cell factors

Table 13-1 Comparison of standards from JAMSTEC and SIO

Table 14-1 The standard deviation of the differences between duplicate samples

Table 14-2 The results of the quality control samples at the same depth

Table 14-3 The results of the repeat analysis as a range of concentration

Table 15-1 The Chl. a and Chl. b concentration.

Table 16-1 List of drifters deployed on this cruise

Table 19-1 Weather observation record

Table 21-1 Comparison between primary and secondary temperature sensors

Table 21-2 Salinity comparison between primary and secondary sensors

Table 21-3 CTD salinity from primary sensors at nominal depths

Table 21-4 Difference between CTD salinity and AUTOSAL salinity at selected depths

# List of Figures

Figure 2-1 Track chart

Figure 4-1a Preliminary section of salinity along 6N taken from the CTD stations

Figure 4-1b Preliminary section of temperature along 6N taken from the CTD stations

Figure 4-2a Preliminary section of salinity along PR24 taken from the CTD stations

Figure 4-2b Preliminary section of temperature along PR24 taken from the CTD stations

Figure 4-3a Preliminary section of salinity along PR1S taken from the CTD stations

Figure 4-3b Preliminary section of temperature along PR1S taken from the CTD stations

Figure 8-1 Results from TCCOMP

Figure 9-1 The TMN mooring site

Figure 9-2 The TMS mooring site

Figure 9-3 The mooring line at TMN

Figure 9-4 The mooring line at TMS

Figure 9-5 The marker buoy

Figure 11-1 Computer systems for CTD data processing

Figure 11-2 total salinity spike area variability for time lag between temperature and conductivity at cast 6N021 and K1S181.

Figure 11-3 Pressure variability

Figure 11-4 Variability of deck pressure

Figure 11-5 Calibration of pressure sensor

Figure 11-6 Data flow of CTD data processing

Figure 14-1 Flow diagram for TRAACS800 nitrate method

Figure 14-2 Flow diagram for TRAACS800 nitrite method

Figure 14-3 Flow diagram for TRAACS800 silicate method

Figure 14-4 Flow diagram for TRAACS800 phosphate method

Figure 17-1 Distribution of atmospheric and oceanic CO<sub>2</sub>

Figure 21-1a

Figure 21-1b

Figure 21-2a

Figure 21-2b

Figure 21-3

Figure 21-4

Figure 21-5

# 1. Highlight

by K. Muneyama (4 March 1994)

Chief Scientist: Kei Muneyama, JAMSTEC, Japan

Co-Chief Scientist: Syaefudin, BPPT, Indonesia

Co-Chief Scientist: Michio Aoyama, JAMSTEC, Japan

Cruise: KAIYO-9307

Dates: 12 February to 3 March 1994

Ship: R/V Kaiyo

Ports of call: Marakal, Palau to Marakal, Palau

Although our first plan was to observe PR23, 7.30'N section between Mindanao and Palau, shiptime restricted us to carry out to observe this WOCE designated section. We planned instead to observe (7-30'N, 134-00'E) to (6-00'N, 130-00'E) to (6-00'N, 127-30'E).

Oneday before we would leave Koror, Palau for the cruise, a sudden request were made for us to search 5 missing Japanese divers and one Palauan diving instructor at a remote island some 60 n.miles apart. Next day R/V KAIYO left Koror for search of the 6 missing persons. This search was kept for 5 days from February 7 to 11. We started the WOCE cruise at (7-00'N, 134-00'E) to (6-00'N, 130-00'E) to (6-00'N, 127-30'E) on February 12 1994. As this section is not PR23, we designated it simply 6N. This 6N section consists 15 stations(STN 1-15), and required us 5 days for completion. Station spacing was 30 n.miles from the start to the end of this section.

PR24 section is extended from K6N STN 15(6-00'N, 127-30'E) to PR24 STN 20 (1-33.3'N, 129-40.0'E). Station spacing was kept less than 30 n.miles in this section. Stations 5, 12, 13, 18 and 21 were excluded to save shiptime.

We added an optional section PR24-2 because current flows in this region are known to be complex by the previous observation executed last year. We have deployed ADCP moorings at 4-01.239'N, 127-30.634'E and 3-10.793'N, 128-27.367E with double acoustic releasers for each mooring.

PR1S section (S means southern part of PR1) occupies between PR1S STN 1( 0-45'N, 130-00'E) and PR1S STN 25(10-00'N, 130-00'E). The lack of shiptime has forced

us to delete STNs 3, 5, 7, 10, 14, 22, 23, 24 and 25. We carried out observations from 0-45'N to 8-00'N on the 130E by 30 n.miles of station spacing. We deployed 8 surface drifters between 2-00'N and 8-00'N on 130-00'E. We arrived at Koror on March 3rd.

A General Oceanics (GO) 36 position rosette water sampler with 12 liter Niskin bottles has worked well with a Sea Bird Electronics CTD 9-11 plus deck unit. If we did not have a 36 position rosette water sampler, our cruise track had to be forced notably to change due to 5 days reduction for the unfortunate accident. Our preliminary survey of PR24 region executed in 1992 has told us a very steep topographic change. We installed two altimeters to the GO 36 position water sampler, one Benthos' model 2110-1 and another Datasonic PSA-900A. Nevertheless we did not notice at one occasion that the wirecable was bent almost rectangularly at the top of protection frame of the rosette as wirecable was hooked to a Niskin bottle until the CTD/rosette surfaced obliquely.

We used 12 position rosette water sampler at PR24-2 section as the topography there is very steep.

We had paid attention to the length difference of CTD/rosette water sampler between the reading of CTD pressure and the wire-out measurement of the winch.

The analysis of CTD corrected by the Autosal indicate that they meet WHP quality guideline for precision and accuracy. Salinity measurement due to bottle samplings has shown ca. 0.001 PSS in accuracy and ca. 0.0005 PSS in precision. The precision of dissolved oxygen (DO.) measurement is ca. 0.5% and its accuracy is ca. 0.1% when the interlab comparison of the standard solution at ODF/SIO is adopted. The precision of nitrate analysis is ca. 0.4% , that of silicate analysis is ca. 0.4% and that of phosphate analysis is ca. 1.2% when experiments tried at duplicative water samples below 3000m depth is adopted.

## 2. Summary of the observations and data files

by M. Aoyama ( 10 March 1994)

The ship's track is shown in Figure 2-1.

Station positions and all scientific events are in the WOCE format KYZZZ94.SUM file and shown in Table 2-1.

K6NZZZ94.SEA, K24ZZZ94.SEA and K1SZZZ94.SEA are the WOCE format ---.SEA files for section 6N, PR24 and PR1S, respectively. The ---.SEA files for section TM (from Talaud Is. to Morotai Is.) are not reported.

The WOCE format ---.CTD files are named as follows;

1st digit: K ( This means KAIYO)

2nd and 3rd digits: line designator

4th and 5th digits: station number

6th digits: cast number

7th and 8th digit: the last two digits of the year

For example, the ---.CTD file name of the first cast at the station 15 on section PR1S becomes K1S15194.CTD.

In each ---.SUM, ---.SEA and ---.CTD files, we use "KY " as a ship code.

Sampling accomplished:

57 CTD/Rosette stations and 3 trial casts were occupied.

Number of water samples analyzed:

Salinity ca. 1600

Oxygen 1602

Nutrients ca. 1600

Plant Pigment 73

Number of water samples collected for shore-based analysis:

AMS radiocarbon ca. 220 (7 stations, all replicate samples)

8 drifters were deployed.

2 ADCP moorings were deployed.

Measurements of surface layer pCO<sub>2</sub> and atmospheric pCO<sub>2</sub> were made along the entire ship track.

Table 2-1 KYZZZ94.SUM

R/V KAIYO(Country code 49,ship code is KY) Expedition designation--cruise number K9307/leg 3 along WHP section PR24 and PR1S

EXPOCODE	WHP-ID	STNNBR	NO	TYPE	DATE	TIME	CODE	POSITION	CODE	UBD	HBD	MW	MAXP	NOB	PARAMETER
COMMENT															
49KYK9307/3	6N	01	1	ROS	021294	0230	BE	06 57.44 N 133 53.08 E	GPS	3206					
49KYK9307/3	6N	01	1	ROS	021294	0328	BO	06 57.47 N 133 53.65 E	GPS	3180	31	3231	3198	27	1-6,34,35
49KYK9307/3	6N	01	1	ROS	021294	0458	EN	06 57.39 N 133 54.02 E	GPS	3160					
49KYK9307/3	6N	02	1	ROS	021294	0742	BE	06 52.07 N 133 30.04 E	GPS	4138					
49KYK9307/3	6N	02	1	ROS	021294	0844	BO	06 52.29 N 133 30.02 E	GPS	4133	27	4113	4166	32	1-6
49KYK9307/3	6N	02	1	ROS	021294	1020	EN	06 52.58 N 133 29.91 E	GPS	4121					
49KYK9307/3	6N	03	1	ROS	021294	1345	BE	06 45.02 N 133 00.09 E	GPS	3606					
49KYK9307/3	6N	03	1	ROS	021294	1451	BO	06 44.84 N 133 00.30 E	GPS	3798	37	3732	3782	31	1-6
49KYK9307/3	6N	03	1	ROS	021294	1628	EN	06 44.44 N 133 01.02 E	GPS	3869					
49KYK9307/3	6N	04	1	ROS	021294	2024	BE	06 36.93 N 132 29.83 E	GPS	4023					
49KYK9307/3	6N	04	1	ROS	021294	2122	BO	06 37.11 N 132 29.83 E	GPS	4026	19	4003	4059	32	1-6,34,35
49KYK9307/3	6N	04	1	ROS	021294	2302	EN	06 37.51 N 132 29.48 E	GPS	4094					
49KYK9307/3	6N	05	1	ROS	021394	0228	BE	06 29.89 N 132 00.09 E	GPS	4853					
49KYK9307/3	6N	05	1	ROS	021394	0344	BO	06 29.98 N 132 00.20 E	GPS	4852	30	4836	4918	35	1-6
49KYK9307/3	6N	05	1	ROS	021394	0523	EN	06 30.24 N 132 00.41 E	GPS	4851					
49KYK9307/3	6N	06	1	ROS	021394	0834	BE	06 22.08 N 131 30.20 E	GPS	5257					
49KYK9307/3	6N	06	1	ROS	021394	0950	BO	06 22.29 N 131 30.21 E	GPS	5258	20	5263	5354	36	1-6
49KYK9307/3	6N	06	1	ROS	021394	1145	EN	06 22.74 N 131 30.19 E	GPS	5255					
49KYK9307/3	6N	07	1	ROS	021394	1529	BE	06 14.95 N 131 00.06 E	GPS	5525					
49KYK9307/3	6N	07	1	ROS	021394	1649	BO	06 15.62 N 131 00.49 E	GPS	5539	50	5743	5620	36	1-6
49KYK9307/3	6N	07	1	ROS	021394	1850	EN	06 14.46 N 130 58.89 E	GPS	5524					
49KYK9307/3	6N	08	1	ROS	021394	2209	BE	06 07.04 N 130 29.95 E	GPS	5541					
49KYK9307/3	6N	08	1	ROS	021394	2327	BO	06 07.26 N 130 29.35 E	GPS	5541	47	5615	5625	36	1-6,34,35
49KYK9307/3	6N	08	1	ROS	021494	0139	EN	06 07.63 N 130 28.27 E	GPS	5539					
49KYK9307/3	6N	09	1	ROS	021494	0728	BE	06 00.36 N 129 59.81 E	GPS	5476					
49KYK9307/3	6N	09	1	ROS	021494	0853	BO	06 00.64 N 130 00.24 E	GPS	5470	18	5538	5579	36	1-6
49KYK9307/3	6N	09	1	ROS	021494	1045	EN	06 01.13 N 130 00.55 E	GPS	5478					
49KYK9307/3	6N	10	1	ROS	021494	1424	BE	06 00.04 N 129 29.89 E	GPS	5555					
49KYK9307/3	6N	10	1	ROS	021494	1549	BO	06 00.07 N 129 29.95 E	GPS	5567	25	5556	5660	36	1-6
49KYK9307/3	6N	10	1	ROS	021494	1741	EN	06 00.34 N 129 30.27 E	GPS	5565					
49KYK9307/3	6N	11	1	ROS	021494	2045	BE	06 00.08 N 128 59.96 E	GPS	5328					
49KYK9307/3	6N	11	1	ROS	021494	2211	BO	06 00.46 N 129 00.10 E	GPS	5349	22	5350	5405	36	1-6,34,35
49KYK9307/3	6N	11	1	ROS	021594	0015	EN	06 00.87 N 129 00.80 E	GPS	5429					
49KYK9307/3	6N	12	1	ROS	021594	0523	BE	06 00.11 N 128 29.89 E	GPS	4640					
49KYK9307/3	6N	12	1	ROS	021594	0630	BO	06 00.56 N 128 29.34 E	GPS	4654	47	4738	4670	36	1-6
49KYK9307/3	6N	12	1	ROS	021594	0810	EN	06 00.52 N 128 28.07 E	GPS	4649					
49KYK9307/3	6N	13	1	ROS	021594	1122	BE	05 59.99 N 127 59.96 E	GPS	5537					
49KYK9307/3	6N	13	1	ROS	021594	1245	BO	05 59.68 N 127 59.57 E	GPS	5547	47	5585	5628	36	1-6
49KYK9307/3	6N	13	1	ROS	021594	1442	EN	05 59.19 N 127 59.32 E	GPS	5553					
49KYK9307/3	6N	14	1	ROS	021594	1744	BE	05 59.91 N 127 30.00 E	GPS	8573					
49KYK9307/3	6N	14	1	ROS	021594	2040	BO	05 58.40 N 127 28.97 E	GPS	8680		7646	7680	36	1-6,34,35
49KYK9307/3	6N	14	1	ROS	021694	0006	EN	05 57.56 N 127 28.51 E	GPS	8435					
49KYK9307/3	6N	15	1	ROS	021694	0408	BE	05 59.69 N 126 59.86 E	GPS	3836					
49KYK9307/3	6N	15	1	ROS	021694	0510	BO	05 59.75 N 126 59.42 E	GPS	3782	20	3796	3826	36	1-6

10 WHP Leg 3  
 10 WHP Leg 3  
 10 WHP Leg 3

49KYK9307/3	GN	15	1	ROS	021694	0640	EN	05	59.65	N	126	59.20	E	GPS	3746				
49KYK9307/3	PR24	01	1	ROS	021694	0845	BE	05	43.04	N	127	09.75	E	GPS	5357				
49KYK9307/3	PR24	01	1	ROS	021694	1006	BO	05	43.35	N	127	09.41	E	GPS	5270	48	5345	5420	36 1-6
49KYK9307/3	PR24	01	1	ROS	021694	1159	EN	05	43.59	N	127	09.22	E	GPS	5267				
49KYK9307/3	PR24	02	1	ROS	021694	1642	BE	05	25.18	N	127	19.38	E	GPS	5564				
49KYK9307/3	PR24	02	1	ROS	021694	1757	BO	05	25.64	N	127	18.89	E	GPS	5733	75	5668	5709	36 1-6
49KYK9307/3	PR24	02	1	ROS	021694	1943	EN	05	26.45	N	127	18.71	E	GPS	5725				
49KYK9307/3	PR24	03	1	ROS	021694	2217	BE	05	10.28	N	127	29.83	E	GPS	6316				
49KYK9307/3	PR24	03	1	ROS	021694	2343	BO	05	10.53	N	127	28.52	E	GPS	6390	20	6419	6548	36 1-6, 34, 35
49KYK9307/3	PR24	03	1	ROS	021794	0157	EN	05	11.14	N	127	29.80	E	GPS	6608				
49KYK9307/3	PR24	04	1	ROS	021794	0648	BE	04	52.79	N	127	39.88	E	GPS	4017				
49KYK9307/3	PR24	04	1	ROS	021794	0745	BO	04	53.36	N	127	39.84	E	GPS	4031	30	4010	4023	36 1-6
49KYK9307/3	PR24	04	1	ROS	021794	0908	EN	04	53.78	N	127	39.75	E	GPS	4056				
49KYK9307/3	PR24	06	1	ROS	021794	1127	BE	04	36.17	N	127	50.18	E	GPS	3199				
49KYK9307/3	PR24	06	1	ROS	021794	1216	BO	04	36.23	N	127	50.47	E	GPS	3178	17	3158	3198	28 1-6
49KYK9307/3	PR24	06	1	ROS	021794	1339	EN	04	36.20	N	127	50.59	E	GPS	3171				
49KYK9307/3	PR24	07	1	ROS	021794	1547	BE	04	20.16	N	128	00.46	E	GPS	2406				
49KYK9307/3	PR24	07	1	ROS	021794	1631	BO	04	20.55	N	128	00.31	E	GPS	2475	38	2509	2470	25 1-6
49KYK9307/3	PR24	07	1	ROS	021794	1735	EN	04	20.39	N	128	00.83	E	GPS	2508				
49KYK9307/3	PR24	08	1	ROS	021794	1947	BE	04	03.39	N	128	10.05	E	GPS	2859				
49KYK9307/3	PR24	08	1	ROS	021794	2039	BO	04	03.62	N	128	10.69	E	GPS	3003		2979	2858	36 1-6
49KYK9307/3	PR24	08	1	ROS	021794	2152	EN	04	04.32	N	128	11.21	E	GPS	3209				
49KYK9307/3	PR24	09	1	ROS	021894	0025	BE	03	46.64	N	128	20.11	E	GPS	1989				
49KYK9307/3	PR24	09	1	ROS	021894	0107	BO	03	47.02	N	128	20.22	E	GPS	2060	95	1964	1972	36 1-6, 34, 35
49KYK9307/3	PR24	09	1	ROS	021894	0212	EN	03	47.58	N	128	20.27	E	GPS	2126				
49KYK9307/3	PR24	11	1	ROS	021894	1027	BE	03	21.67	N	128	34.96	E	GPS	3492				
49KYK9307/3	PR24	11	1	ROS	021894	1139	BO	03	22.04	N	128	34.76	E	GPS	3483	18	3466	3505	28 1-6
49KYK9307/3	PR24	11	1	ROS	021894	1308	EN	03	22.35	N	128	34.51	E	GPS	3441				
49KYK9307/3	PR24	12	1	ROS	021894	1458	BE	03	09.13	N	128	42.49	E	GPS	3537				
49KYK9307/3	PR24	12	1	ROS	021894	1604	BO	03	09.50	N	128	42.37	E	GPS	3551	30	3552	3592	30 1-6
49KYK9307/3	PR24	12	1	ROS	021894	1739	EN	03	09.97	N	128	42.28	E	GPS	3566				
49KYK9307/3	PR24	14	1	ROS	021894	1926	BE	02	56.58	N	128	50.23	E	GPS	3491				
49KYK9307/3	PR24	14	1	ROS	021894	2026	BO	02	56.91	N	128	50.01	E	GPS	3489	20	3474	3515	36 1-6
49KYK9307/3	PR24	14	1	ROS	021894	2200	EN	02	57.55	N	128	49.46	E	GPS	3479				
49KYK9307/3	PR24	15	1	ROS	021994	0018	BE	02	40.01	N	129	00.00	E	GPS	4169				
49KYK9307/3	PR24	15	1	ROS	021994	0125	BO	02	40.12	N	129	00.03	E	GPS	4175	18	4154	4211	36 1-6, 34, 35
49KYK9307/3	PR24	15	1	ROS	021994	0307	EN	02	40.43	N	129	00.22	E	GPS	4182				
49KYK9307/3	TM	01	1	ROS	021994	0800	BE	02	50.63	N	128	42.13	E	GPS	1769				
49KYK9307/3	TM	01	1	ROS	021994	0850	BO	02	51.05	N	128	41.65	E	GPS	1769	21	1733	1742	12 1-6
49KYK9307/3	TM	01	1	ROS	021994	0932	EN	02	51.53	N	128	41.46	E	GPS	1827				
49KYK9307/3	TM	02	1	ROS	021994	1147	BE	03	00.12	N	128	24.10	E	GPS	2923				
49KYK9307/3	TM	02	1	ROS	021994	1251	BO	03	00.36	N	128	24.12	E	GPS	2924	26	2913	2941	12 1-6
49KYK9307/3	TM	02	1	ROS	021994	1350	EN	03	00.63	N	128	24.11	E	GPS	2881				
49KYK9307/3	TM	03	1	ROS	021994	1528	BE	03	13.05	N	128	18.94	E	GPS	3452				
49KYK9307/3	TM	03	1	ROS	021994	1644	BO	03	13.75	N	128	18.72	E	GPS	3465	20	3432	3448	12 1-6
49KYK9307/3	TM	03	1	ROS	021994	1738	EN	03	14.22	N	128	18.57	E	GPS	3396				
49KYK9307/3	TM	04	1	ROS	021994	1917	BE	03	27.07	N	128	13.18	E	GPS	1964				

49KYK9307/3	TM 04	1	ROS 021994	2002	BO 03	27.51	N 128	12.98	E GPS	1891	26	1867	1873	12	1-6
49KYK9307/3	TM 04	1	ROS 021994	2049	EN 03	27.77	N 128	12.87	E GPS	1824					
49KYK9307/3	TM 05	1	ROS 021994	2218	BE 03	37.99	N 128	05.10	E GPS	1224					
49KYK9307/3	TM 05	1	ROS 021994	2255	BO 03	38.42	N 128	05.23	E GPS	1181	48	1146	1143	12	1-6
49KYK9307/3	TM 05	1	ROS 021994	2330	EN 03	38.67	N 128	05.32	E GPS	1144					
49KYK9307/3	TM 06	1	ROS 022094	0056	BE 03	45.98	N 127	57.06	E GPS	1081					
49KYK9307/3	TM 06	1	ROS 022094	0143	BO 03	46.46	N 127	57.50	E GPS	1078	39	1136	1047	12	1-6
49KYK9307/3	TM 06	1	ROS 022094	0219	EN 03	46.65	N 127	57.71	E GPS	1069					
49KYK9307/3	TM 07	1	ROS 022094	0424	BE 03	53.11	N 127	46.11	E GPS	291					
49KYK9307/3	TM 07	1	ROS 022094	0438	BO 03	53.20	N 127	46.29	E GPS	291	20	275	276	12	1-6
49KYK9307/3	TM 07	1	ROS 022094	0455	EN 03	53.30	N 127	46.44	E GPS	294					
49KYK9307/3	TM 08	1	ROS 022094	0557	BE 03	56.93	N 127	39.03	E GPS	741					
49KYK9307/3	TM 08	1	ROS 022094	0624	BO 03	56.92	N 127	39.04	E GPS	742	20	678	684	12	1-6
49KYK9307/3	TM 08	1	ROS 022094	0653	EN 03	56.98	N 127	39.05	E GPS	693					
49KYK9307/3	TM 09	1	ROS 022094	0832	BE 04	03.90	N 127	25.78	E GPS	3224					
49KYK9307/3	TM 09	1	ROS 022094	0945	BO 04	03.81	N 127	25.52	E GPS	3242	22	3221	3251	12	1-6
49KYK9307/3	TM 09	1	ROS 022094	1045	EN 04	03.95	N 127	25.53	E GPS	3241					
49KYK9307/3	TM 10	1	ROS 022094	1211	BE 04	10.01	N 127	15.02	E GPS	1731					
49KYK9307/3	TM 10	1	ROS 022094	1248	BO 04	10.21	N 127	14.93	E GPS	1694	27	1679	1693	12	1-6
49KYK9307/3	TM 10	1	ROS 022094	1329	EN 04	10.43	N 127	14.77	E GPS	1662					
49KYK9307/3	PR24 16	1	ROS 022394	2347	BE 02	23.26	N 129	10.03	E GPS	3428					
49KYK9307/3	PR24 16	1	ROS 022494	0043	BO 02	23.48	N 129	09.89	E GPS	3430	16	3408	3440	36	1-6, 34, 35
49KYK9307/3	PR24 16	1	ROS 022494	0215	EN 02	23.64	N 129	09.65	E GPS	3371					
49KYK9307/3	PR24 17	1	ROS 022494	0430	BE 02	06.20	N 129	19.87	E GPS	3440					
49KYK9307/3	PR24 17	1	ROS 022494	0529	BO 02	06.68	N 129	19.71	E GPS	3640	48	3593	3597	36	1-6
49KYK9307/3	PR24 17	1	ROS 022494	0701	EN 02	07.19	N 129	19.31	E GPS	3676					
49KYK9307/3	PR24 19	1	ROS 022494	0903	BE 01	50.01	N 129	30.02	E GPS	4721					
49KYK9307/3	PR24 19	1	ROS 022494	1017	BO 01	50.22	N 129	29.77	E GPS	4727	13	4733	4804	36	1-6
49KYK9307/3	PR24 19	1	ROS 022494	1232	EN 01	50.60	N 129	29.06	E GPS	4738					
49KYK9307/3	PR24 20	1	ROS 022494	1441	BE 01	33.32	N 129	40.04	E GPS	4275					
49KYK9307/3	PR24 20	1	ROS 022494	1550	BO 01	33.55	N 129	39.84	E GPS	4270	18	4777	4315	36	1-6
49KYK9307/3	PR24 20	1	ROS 022494	1733	EN 01	33.94	N 129	40.04	E GPS	4257					
49KYK9307/3	PR1S 01	1	ROS 022494	2243	BE 00	44.98	N 130	00.05	E GPS	1450					
49KYK9307/3	PR1S 01	1	ROS 022494	2314	BO 00	45.25	N 130	00.05	E GPS	1526	46	1444	1447	21	1-6, 12, 34, 35
49KYK9307/3	PR1S 01	1	ROS 022594	0010	EN 00	45.34	N 129	59.86	E GPS	1501					
49KYK9307/3	PR1S 02	1	ROS 022594	0216	BE 00	59.98	N 129	59.99	E GPS	3021					
49KYK9307/3	PR1S 02	1	ROS 022594	0310	BO 01	00.19	N 129	59.73	E GPS	3020	19	3021	3026	36	1-6
49KYK9307/3	PR1S 02	1	ROS 022594	0431	EN 01	00.54	N 129	59.44	E GPS	3021					
49KYK9307/3	PR1S 04	1	ROS 022594	0744	BE 01	29.96	N 130	00.98	E GPS	4108					
49KYK9307/3	PR1S 04	1	ROS 022594	0854	BO 01	30.16	N 129	59.72	E GPS	4124	12	4117	4165	36	1-6, 12
49KYK9307/3	PR1S 04	1	ROS 022594	1045	EN 01	30.34	N 129	59.69	E GPS	4133					
49KYK9307/3	PR1S 06	1	ROS 022594	1403	BE 02	00.09	N 129	59.93	E GPS	4396					
49KYK9307/3	PR1S 06	1	ROS 022594	1516	BO 02	00.25	N 129	59.66	E GPS	4395	14	4387	4450	36	1-6
49KYK9307/3	PR1S 06	1	ROS 022594	1658	EN 02	00.32	N 129	59.04	E GPS	4394					
49KYK9307/3	PR1S 08	1	ROS 022594	2008	BE 02	30.00	N 129	59.95	E GPS	4015					
49KYK9307/3	PR1S 08	1	ROS 022594	2115	BO 02	29.97	N 129	59.88	E GPS	4003	15	3982	4042	36	1-6, 34, 35
49KYK9307/3	PR1S 08	1	ROS 022594	2250	EN 02	29.84	N 130	00.06	E GPS	4025					

49KYK9307/3	PR1S 09	1	ROS 022694	0240	BE	03 00.04	N	129	59.92	E	GPS	3052					
49KYK9307/3	PR1S 09	1	ROS 022694	0336	BO	03 00.03	N	129	59.80	E	GPS	3120	29	3102	3139	36	1-6, 12
49KYK9307/3	PR1S 09	1	ROS 022694	0449	EN	02 59.93	N	129	59.94	E	GPS	3083					
49KYK9307/3	PR1S 11	1	ROS 022694	0803	BE	03 29.96	N	130	00.00	E	GPS	4492					
49KYK9307/3	PR1S 11	1	ROS 022694	0923	BO	03 30.33	N	129	59.98	E	GPS	4508	15	4500	4559	36	1-6
49KYK9307/3	PR1S 11	1	ROS 022694	1108	EN	03 30.58	N	130	00.39	E	GPS	4504					
49KYK9307/3	PR1S 12	1	ROS 022694	1412	BE	04 00.00	N	130	00.05	E	GPS	4700					
49KYK9307/3	PR1S 12	1	ROS 022694	1528	BO	04 00.13	N	130	00.19	E	GPS	4707	9	4710	4782	36	1-6
49KYK9307/3	PR1S 12	1	ROS 022694	1714	EN	04 00.53	N	130	00.36	E	GPS	4703					
49KYK9307/3	PR1S 13	1	ROS 022694	2011	BE	04 30.02	N	130	00.15	E	GPS	4760					
49KYK9307/3	PR1S 13	1	ROS 022694	2136	BO	04 30.67	N	130	00.76	E	GPS	4856	30	4879	4868	36	1-6, 12, 34, 35
49KYK9307/3	PR1S 13	1	ROS 022694	2327	EN	04 31.31	N	130	01.57	E	GPS	4883					
49KYK9307/3	PR1S 15	1	ROS 022794	0237	BE	05 00.03	N	130	00.00	E	GPS	5024					
49KYK9307/3	PR1S 15	1	ROS 022794	0407	BO	05 00.24	N	130	00.70	E	GPS	5031	14	5057	5109	36	1-6
49KYK9307/3	PR1S 15	1	ROS 022794	0605	EN	04 59.55	N	130	01.02	E	GPS	5000					
49KYK9307/3	PR1S 16	1	ROS 022794	0914	BE	05 30.05	N	130	00.02	E	GPS	5451					
49KYK9307/3	PR1S 16	1	ROS 022794	1058	BO	05 29.99	N	130	01.22	E	GPS	5436	20	5605	5542	36	1-6
49KYK9307/3	PR1S 16	1	ROS 022794	1302	EN	05 29.89	N	130	02.79	E	GPS	5446					
49KYK9307/3	PR1S 17	1	ROS 022794	1627	BE	05 59.99	N	129	59.92	E	GPS	5454					
49KYK9307/3	PR1S 17	1	ROS 022794	1748	BO	05 59.68	N	129	59.81	E	GPS	5456	17	5488	5563	36	1-6, 12
49KYK9307/3	PR1S 17	1	ROS 022794	1935	EN	05 59.61	N	129	59.48	E	GPS	5470					
49KYK9307/3	PR1S 18	1	ROS 022794	2246	BE	06 30.05	N	129	59.97	E	GPS	5518					
49KYK9307/3	PR1S 18	1	ROS 022894	0006	BO	06 30.06	N	129	59.97	E	GPS	5516	7	5547	5642	36	1-6, 34, 35
49KYK9307/3	PR1S 18	1	ROS 022894	0209	EN	06 30.34	N	130	00.02	E	GPS	5514					
49KYK9307/3	PR1S 19	1	ROS 022894	0532	BE	06 59.97	N	130	00.06	E	GPS	5518					
49KYK9307/3	PR1S 19	1	ROS 022894	0704	BO	07 00.31	N	130	00.74	E	GPS	5521	49	5566	5605	30	1-6, 12
49KYK9307/3	PR1S 19	1	ROS 022894	0907	EN	07 00.72	N	130	01.38	E	GPS	5527					
49KYK9307/3	PR1S 20	1	ROS 022894	2142	BE	07 29.92	N	129	59.35	E	GPS	5514					
49KYK9307/3	PR1S 20	1	ROS 022894	2325	BO	07 30.39	N	129	59.66	E	GPS	5514	24	5546	5625	24	1-6, 12
49KYK9307/3	PR1S 20	1	ROS 030194	0112	EN	07 30.55	N	130	00.04	E	GPS	5510					
49KYK9307/3	PR1S 21	1	ROS 030194	0422	BE	07 59.87	N	129	59.96	E	GPS	5650					
49KYK9307/3	PR1S 21	1	ROS 030194	0617	BO	07 59.85	N	130	00.35	E	GPS	5636	49	5636	5730	24	1-6, 12
49KYK9307/3	PR1S 21	1	ROS 030194	0802	EN	07 59.59	N	130	00.95	E	GPS	5636					

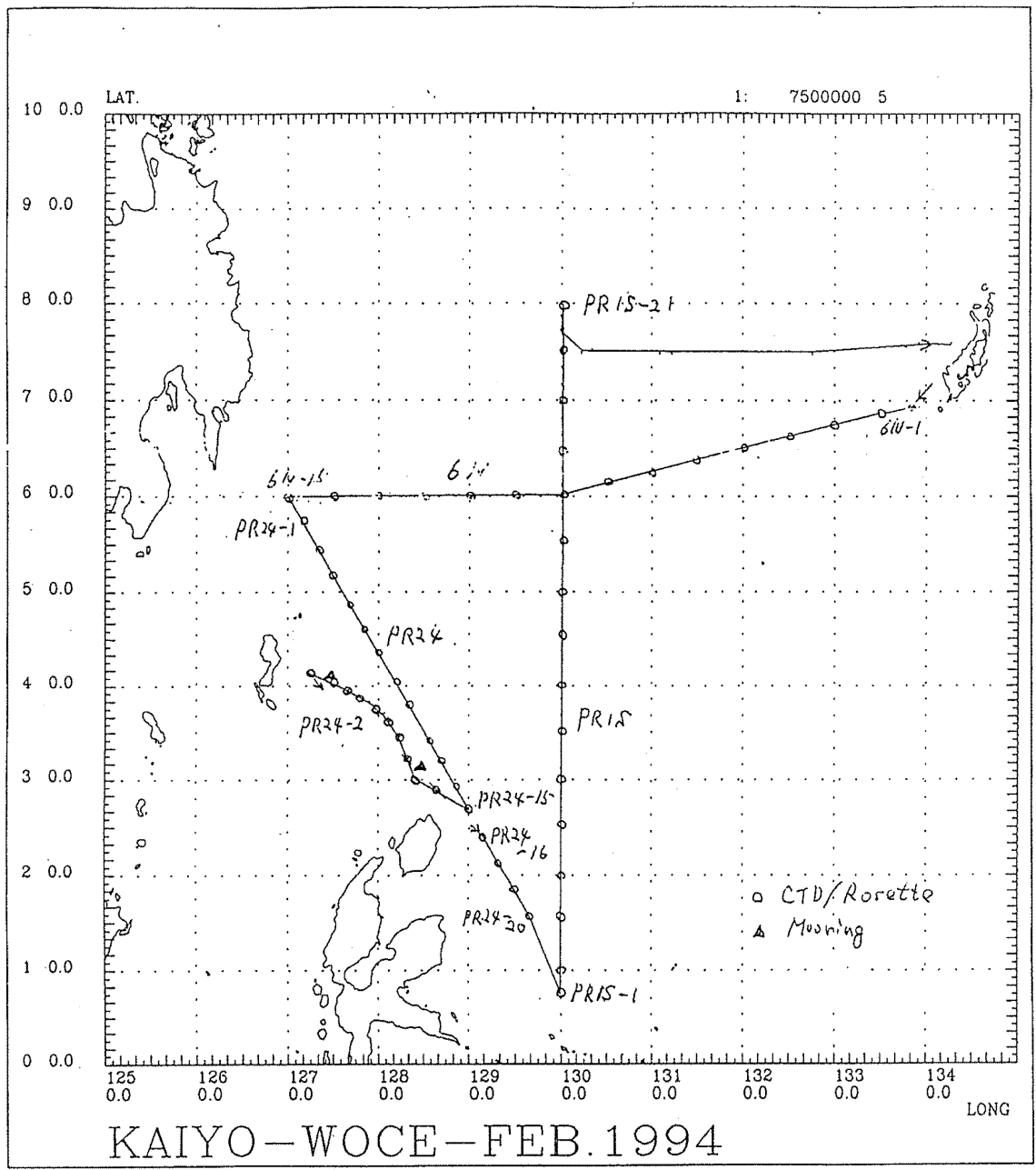

Figure 2-1  
Track chart.

### 3. Cruise Track, Stations and sampling depths

by M. Aoyama (5 March 1994)

The ship's track is shown in Figure 2-1. Station positions are in the KYZZZZ94.SUM file.

The sampling interval from 7-00N, 134-00E to 6-00N, 127-00E was 30 nm. Sampling continued from 6-00N, 127-00E to 2-40N, 129-00E with station interval 20 nm or less across the east mouth of the Celebes Sea along over the 3000 to 6000 meters isobaths just west of the Philippine trench. From 2-40N, 129-00E, we turned toward Talaud Is. and continue to sample at 20 nm interval or less. Stations include over the ridges and trenches between 2-40N, 129-00E and 2-52N, 128-42E. From 2-52N, 128-42E, we turned back to 2-23N, 129-10E and continue to sample at approximately 20 nm interval until we approach 1-33N, 129-40E. Then we turned south to 0-45N, 130-00E and turned north to 8-00N, 130-00E. The sampling interval along 130-00E was at 30 nm .

The sampling depths shallower than 1000 meters were 10, 20, 30, 50, 75, 100, 125, 150, 200, 250, 300, 400, 500, 600, 700, 800, 900, and 1000 meters. Below 1000 meters, the vertical sampling interval is 250 meters and the deepest sampling depth will be up to within 7-50 meters of the bottom. Although our rosette sampler used in section 6N, PR24 and PR1S is 36 positions, 2 casts was not done at few stations deeper than 5000 meters due to save the ship time. At the stations deeper than 5000 meters, we canceled some of the shallower sampling layers. Since the sea condition became hard at the station PR1S-19,20,21, we reduced the Niskin bottles to 30 (at PR1S-19,20), 24 (at PR1S-21) to make the CTD/Rosette operation safety. Since we used 12 position Rosette In the section PR24-2, the sampling depths were largely reduced.

## 4. Preliminary results

by M. Aoyama (22 April 1994)

The temperature and salinity section along 6N, PR24 and PR1S are shown in Fig. 4-1a, 1b, Fig. 4-2a,-2b, and Fig. 4-3a,-3b. The densest water having almost the same properties are found below 4000 db among all stations at the interested area, where the densest water is 27.77 in sigma-theta, 34.679 to 34.680 in salinity, 1.245 to 1.240 in potential temperature. The average and the standard deviation for salinity, temperature, dissolved oxygen, silicate, nitrate and phosphate concentrations are summarized in table 4-1.

As shown in Table 4-1, the deep water properties below 5000 dbar at the stations along 6N, PR24 and PR1S are 1.2395 in potential temperature, 34.6794 in salinity, 150.6 umol/kg in dissolved oxygen, 139.7 umol/kg in silicate concentration, 36.08 umol/kg in nitrate concentration and 2.46 umol/kg in phosphate concentration. The salinity decreased to 34.6748 in the depth between 4000 to 3000 dbar and it becomes variable in five times magnitude larger than that below 5000 dbar.

The distinctive feature in the salinity section along PR1S is the saline water below 4000 dbar around 4 degree north and 5 degree north ( stations PR1S-12,13,15). This saline water is exceeding 34.680 in salinity.

Table 4-1 The average and the standrad deviation of the properties below 3000 dbar.

Range dbar	THETA degree	SALNTY PSS	OXYGEN umol/kg	SILICAT umol/kg	NITRAT umol/kg	PHSPHT umol/kg
7600 - 4998	1.2395 0.0029	34.6794 0.0007	150.6 0.73	139.7 1.06	36.08 0.31	2.46 0.03
6001 - 4998	1.2403 0.0024	34.6793 0.0008	150.6 0.76	139.7 1.14	36.11 0.31	2.47 0.02
5003 - 3996	1.2447 0.0042	34.6790 0.0009	150.4 0.88	139.8 1.22	36.12 0.33	2.47 0.03
4003 - 2998	1.3060 0.0482	34.6748 0.0034	146.79 3.03	140.47 1.26	36.29 0.34	2.48 0.04

### Figure 4-1a 6.3°N TEMPERATURE (C)

12 - 16 Feb 94

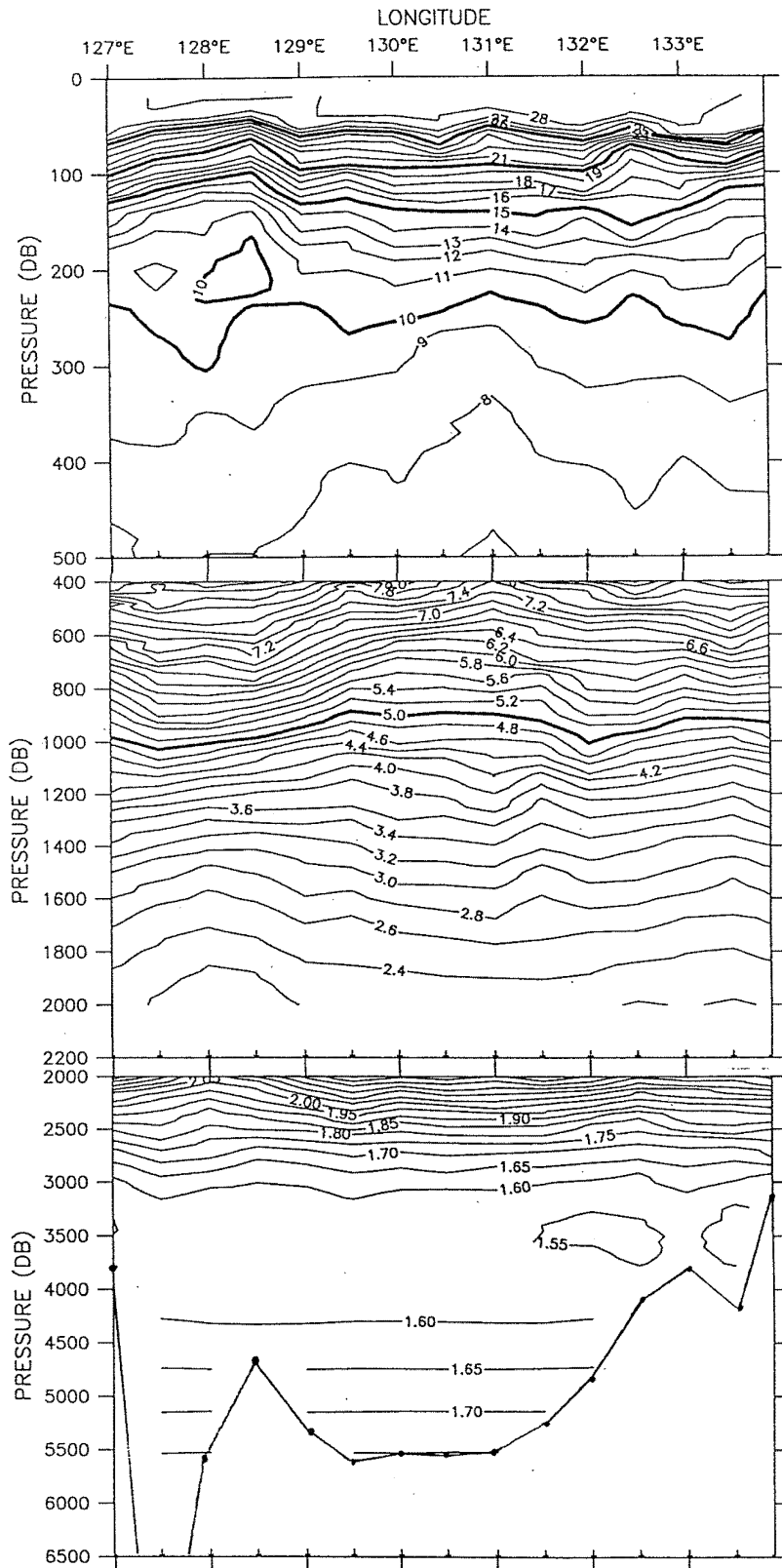

### Figure 4-1b 6.3°N SALINITY (PSU)

12 - 16 Feb 94

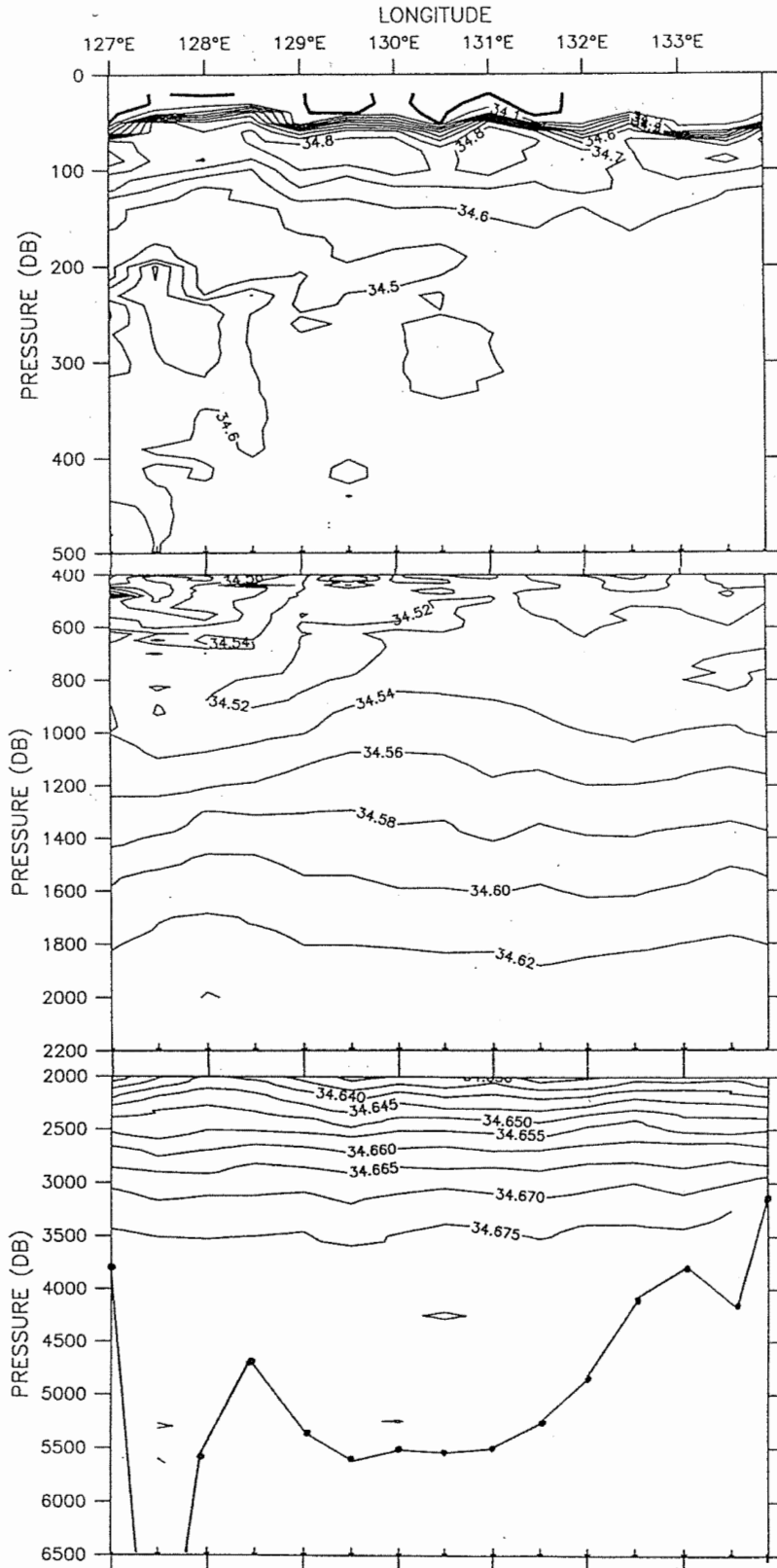

6.0N 127.0E to 7.0N 133.9E

Figure 4-2a 3.6°N 128.4°E TEMPERATURE (C)

16 - 24 Feb 94

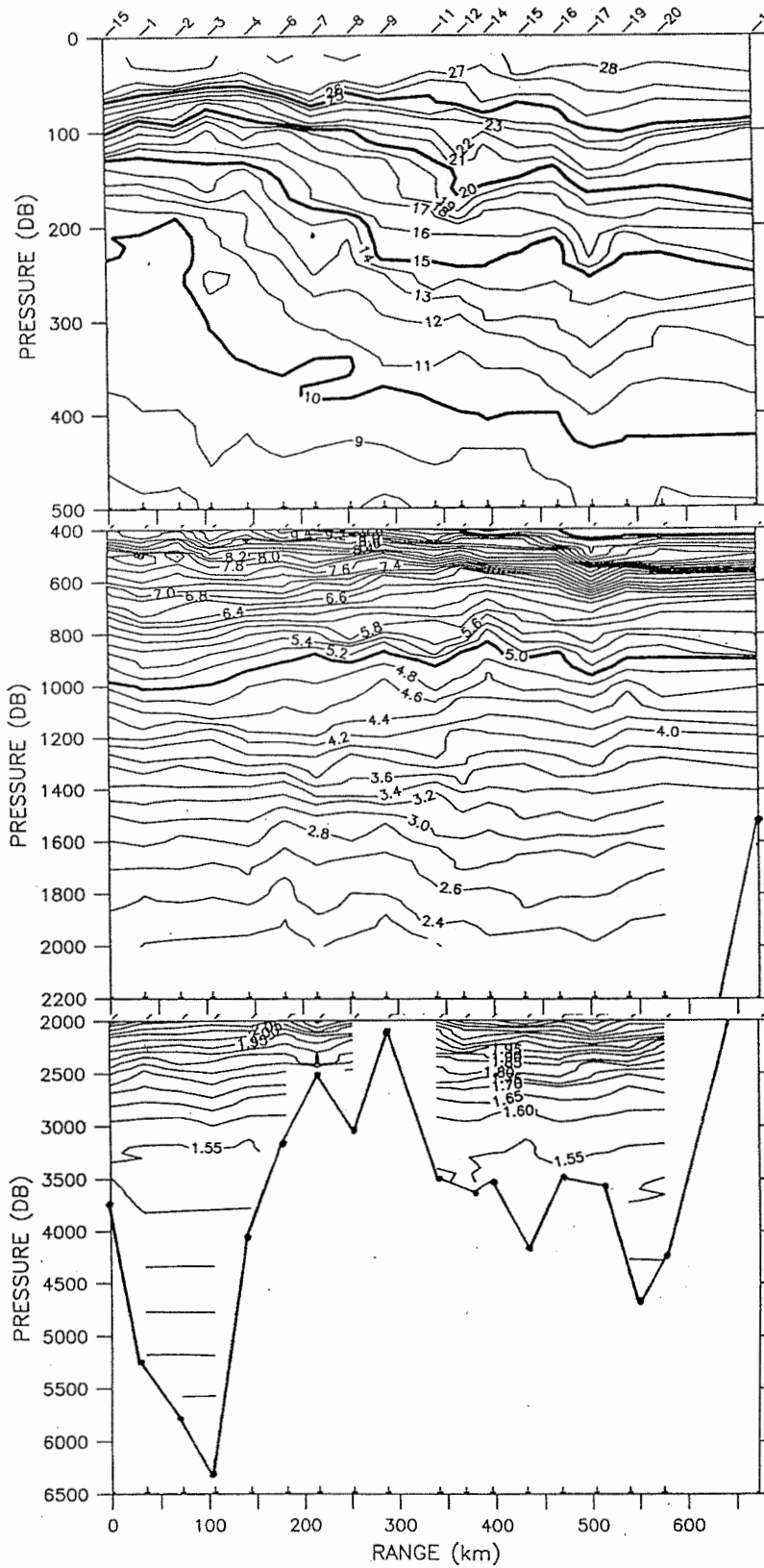

6.0N 127.0E to 0.8N 130.0E

Figure 4-2b 3.6°N 128.4°E SALINITY (PSU)  
16 - 24 Feb 94

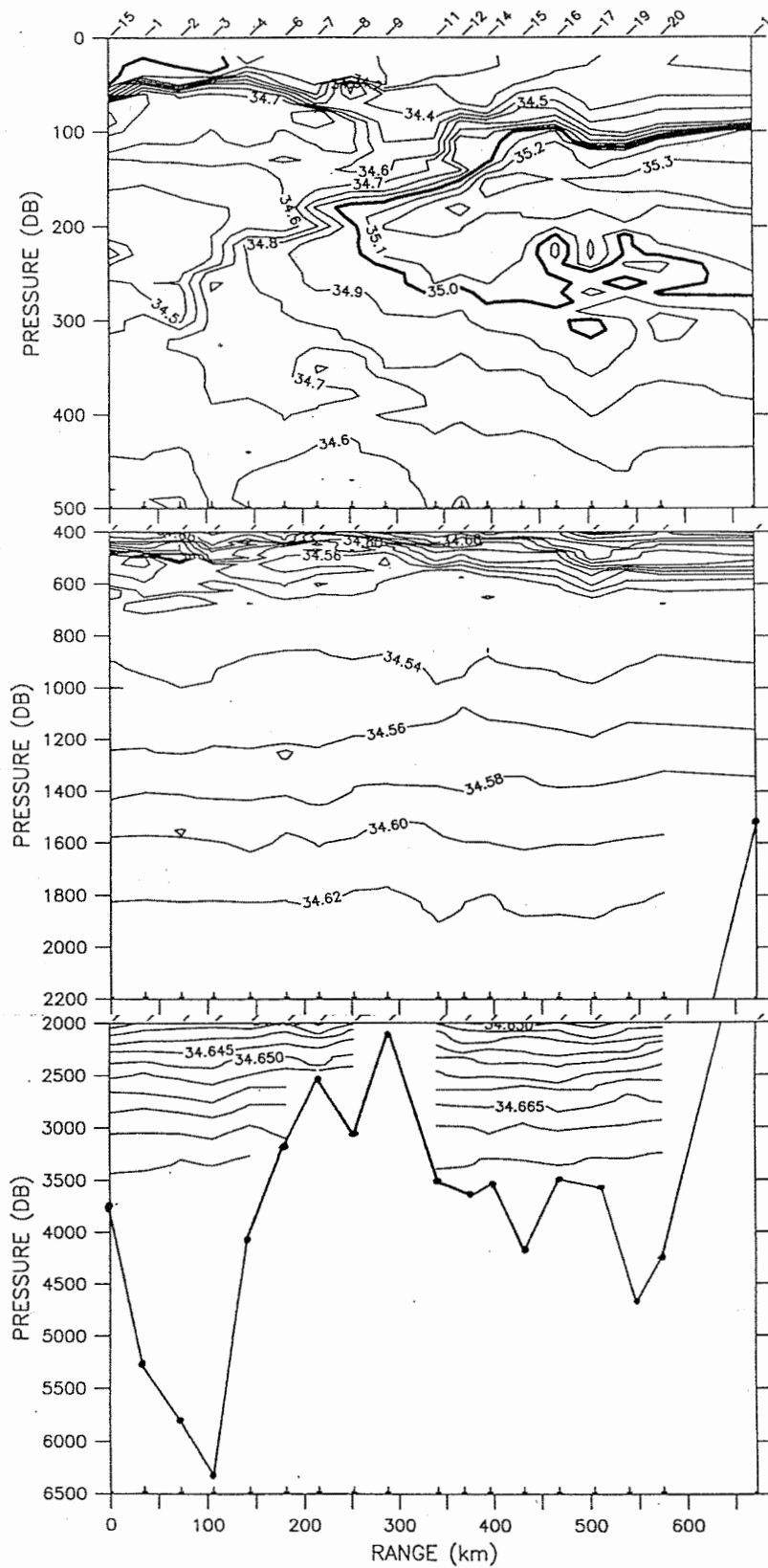

6.0N 127.0E to 0.8N 130.0E

Figure 4-2c 3.6°N 128.0°E TEMPERATURE (C)  
19 - 20 Feb 94

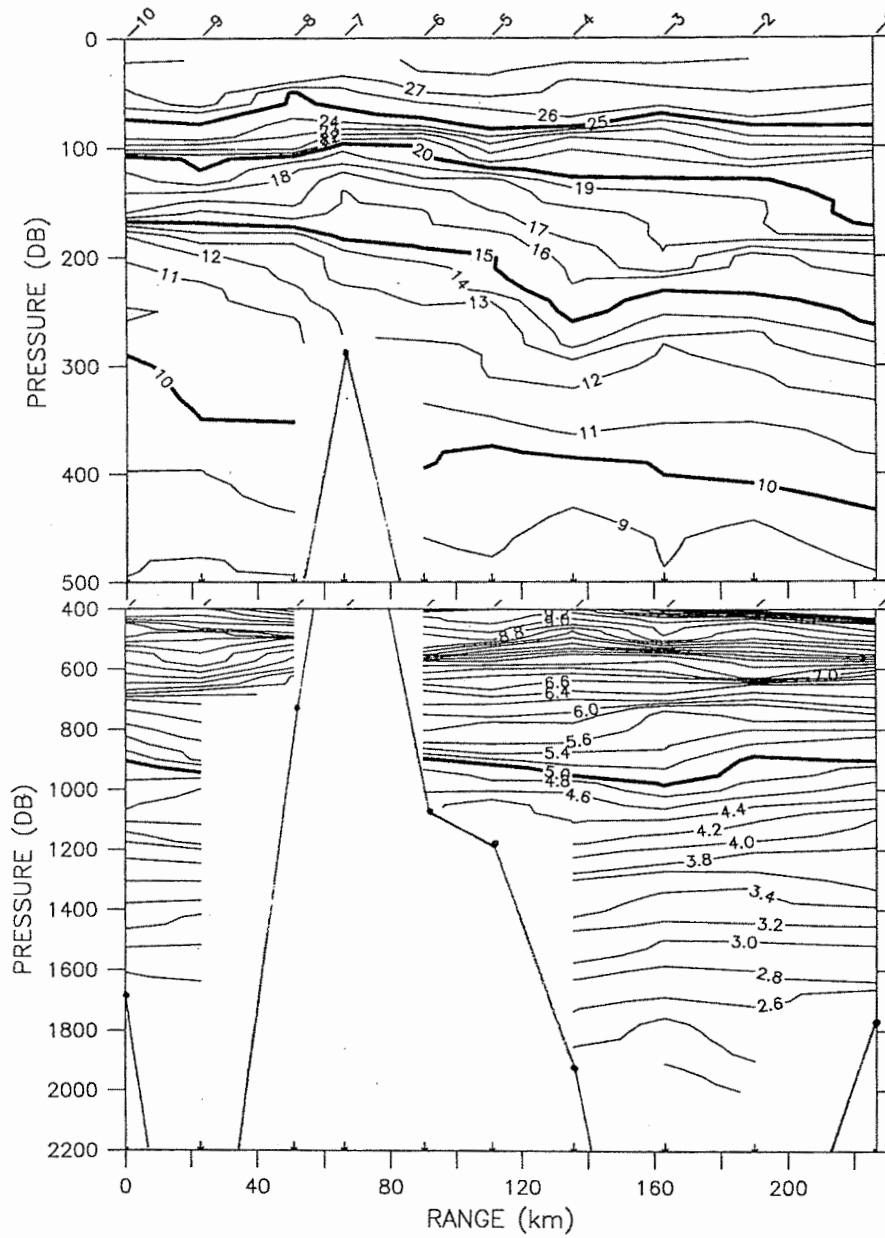

4.2N 127.2E to 2.9N 128.7E

Figure 4-2d 3.6°N 128.0°E SALINITY (PSU)  
19 - 20 Feb 94

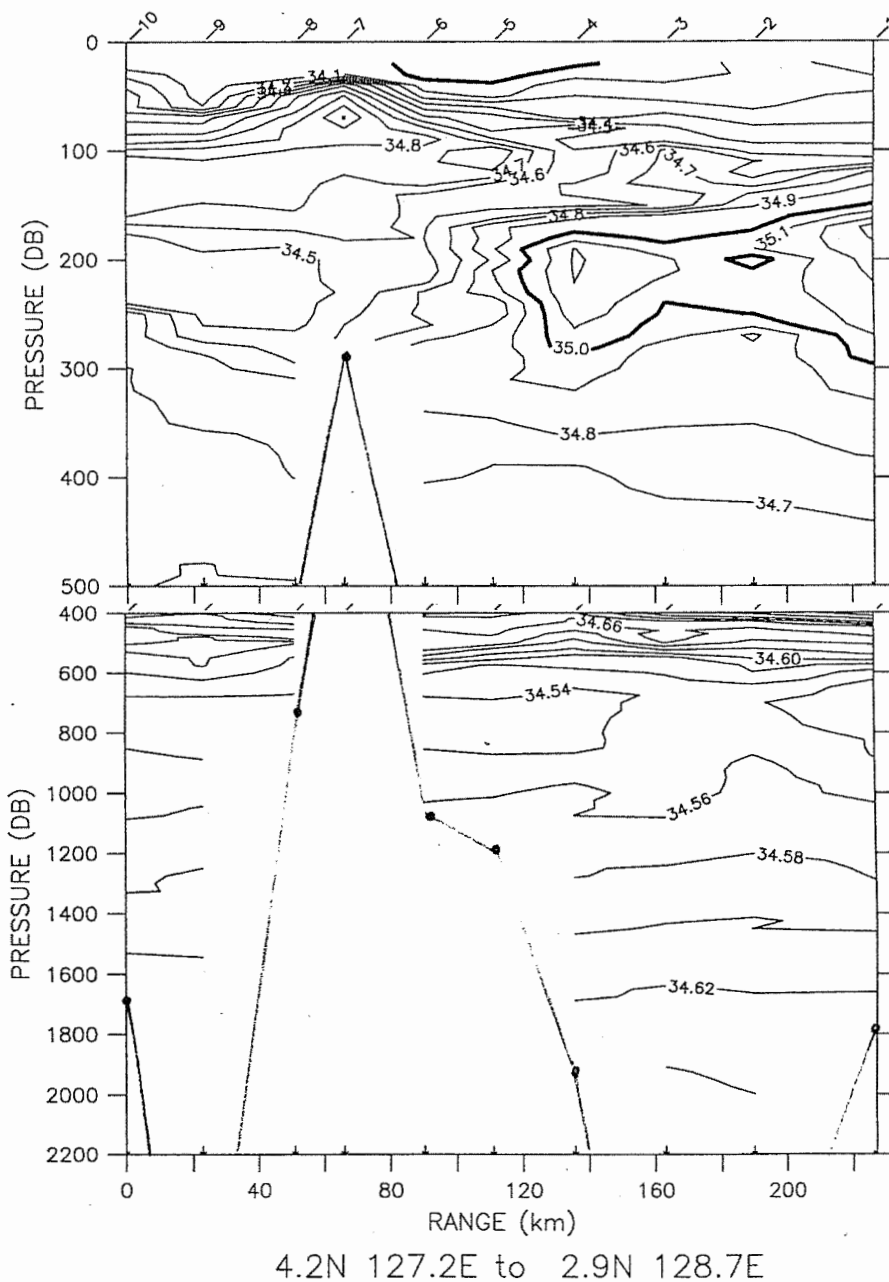
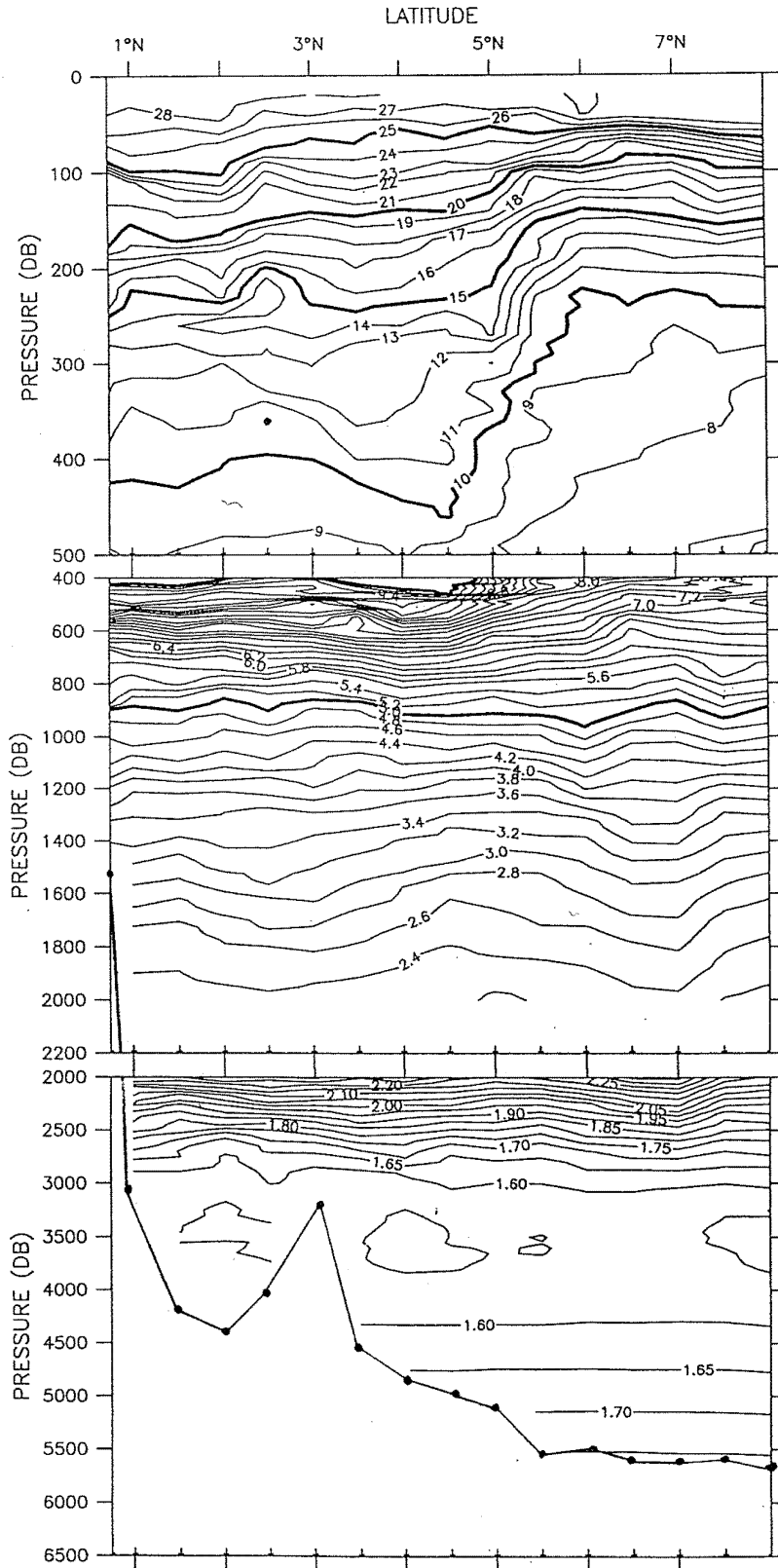

Figure 4-3a 130.0°E TEMPERATURE (C)

24 Feb - 01 Mar 94



0.8N 130.0E to 8.0N 130.0E

Figure 4-3b 130.0°E SALINITY (PSU)  
24 Feb - 01 Mar 94  
LATITUDE

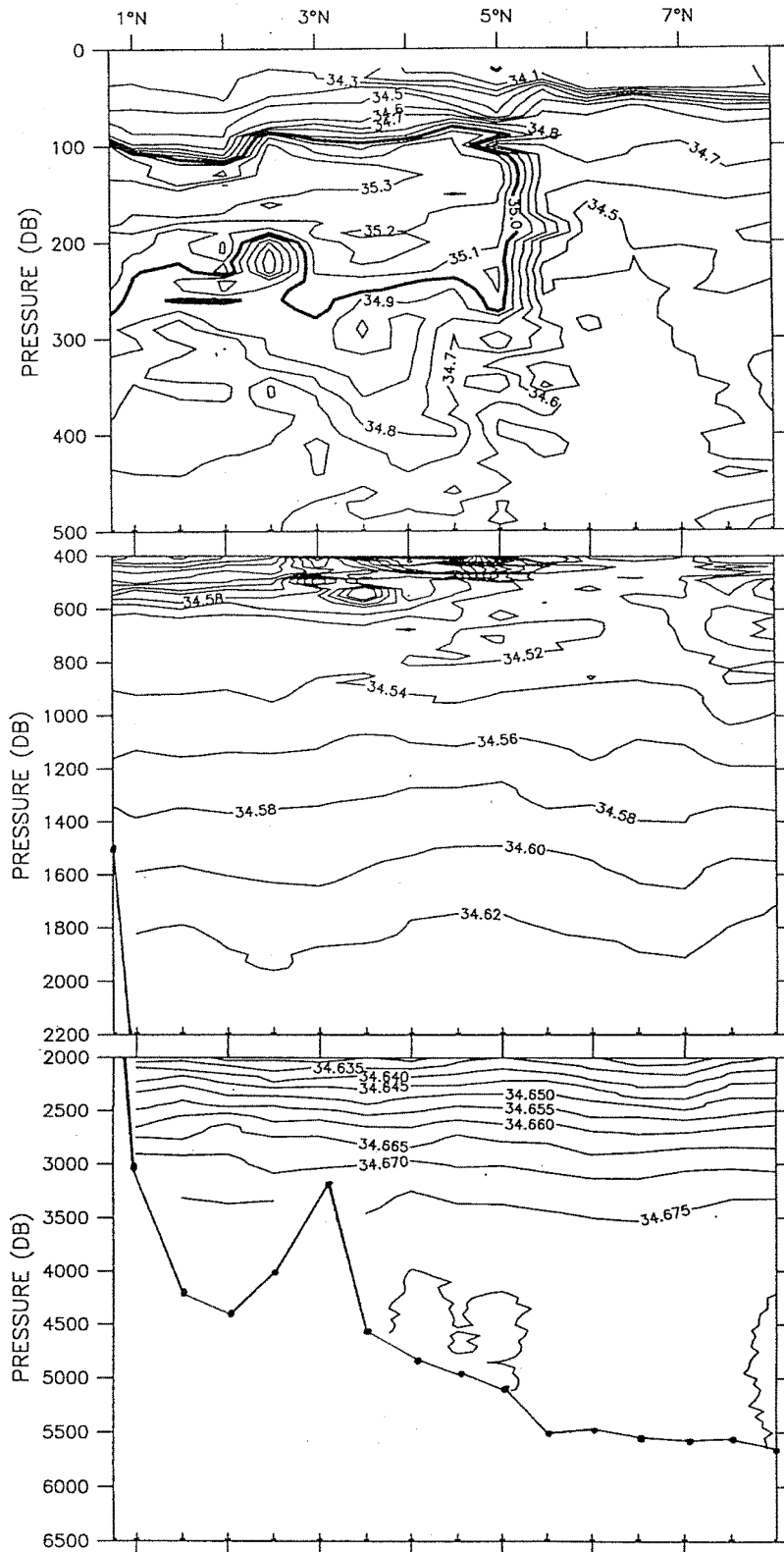

0.8N 130.0E to 8.0N 130.0E

## 5. Parameters, Contribution Institutions, and Personnel

by M. Aoyama (4 March 1994)

The details for these factors are given in Tables 5-1 and 5-2.

Table 5-1: List of parameters to be measured, the sampling group(s) responsible for each, and the Principal Investigator(s) for each.

Parameter / Instr.	Sampling Group	Principal Investigator(s)
CTD/rosette	JAMSTEC	Yuji Kashino and Kentaro Ando
Salinity	JAMSTEC	Takeshi Kawano
O <sub>2</sub> , NO <sub>3</sub> , NO <sub>2</sub> , PO <sub>4</sub> , SiO <sub>2</sub>	JAMSTEC	Michio Aoyama
Mooring	JAMSTEC/STM	Kentaro Ando, Hidetoshi Watanabe and Atsushi Ito
Plant Pigments	BPPT	Rusana Meisianti Djalimun
Surface Drifter	JAMSTEC	Shoichiro Nakamoto
CO <sub>2</sub>	MRI	Hisayuki Y. Inoue
Radiocarbon*	JAMSTEC	Michio Aoyama
Cs-137 and Sr-90**	JAMSTEC/MRI	Michio Aoyama and Katsumi Hirose

\* Funding still Pending.    \*\* Cancelled

Table 5-2: Cruise participants

Cruise participants with role and / or affiliation in parentheses.

Kei Muneyama	JAMSTEC	Chief Scientist
Syaefudin	BPPT	Co-Chief Scientist/CTD
Michio Aoyama	JAMSTEC	Co-Chief Scientist/O2, Nutrients,C-14,Cs-137, Sr-90
Takeshi Kawano	JAMSTEC	Salinity
Yuji Kashino	JAMSTEC	CTD Softwares
Kentaro Ando	JAMSTEC	CTD/rosette hardware/ Mooring
Yudi Anantasena	BPPT	CTD
Rusana Meisianti Djalimun	BPPT	Plant pigments
Akira Sonoda	NME	O2
Hiroshi Yamamoto	NME	CTD/Mooring
Koichi Takao	NME	Salinity
Atsuo Ito	NME	Salinity
Misumi Aoki	NME	O2
Hidetoshi Watanabe	STM	CTD/Mooring
Ranko Takeo	STM	O2
Takehiko Shiribiki	STM	O2
Keiko Komine	STM	Nutrients
Teruhisa Hattori	STM	CTD/Mooring
Hidekazu Ota	KEEC	Nutrients
Kiyotaka Nakao	KEEC	Nutrients
Kazuhiro Murakami	KEEC	CTD/CO2
Richard J. Bauman	SBE	CTD hardware/software support

note: JAMSTEC Japan Marine Science and Technology Center, Japan

BPPT Badan Pengkajian Dan Penerapan Teknologi (Agency for the Assessment and Application of Technology of the Republic of Indonesia), Indonesia

STM Sanyo Techno Marine, Inc., Japan

NME Nippon Marine Enterprises, Ltd., Japan

KEEC Kansai Environmental Engineering Center, Ltd., Japan

SBE Sea-Bird Electronics, Inc., United States of America

MRI Meteorological Research Institute, Japan

## 6. sampling/measurements equipments

by M. Aoyama (4 March 1994)

The details for these factors are given in Tables 6-1.

Table 6-1: Sampling Equipments

---

Small-Volume sampling	:One 36-place rosette (GO1016) with 12-liter bottles. One 24-place rosette (GO1016) with 30-liter bottles. One 12-place rosette (GO1015) with 5-liter bottles for backup.
CTD System:	:One SBE-911plus CTD with altimeter and O2 sensor. Another SBE-911plus with altimeter and O2 sensor for backup. Two SBE-11plus deck units of sampling frequency at 24 Hz.
Winch and cable:	Two Tsurumi Seiki TS-10PVCTD winches having 8000 meters cable of 10.6 mm diameter. The maximum rolling load is 3800 kg x 47 m/minute.
Salinometer:	:Two Guildline Autosal 8400B with HP 2804A quarts thermometer. One ampoule of IAPSO Standard Seawater per station.
Oxygen Analysis:	Carpenter method. Automated potentiometric titration. Two ligs of Metrohm 716 DMS Titrino.
Nutrient Analysis:	Bran Luebbe TRACCS 800 4 channels system.
Plant Pigments	:Shimazu UV2000 Spectrophotometer

---

## 7. Underway Measurement

### a. Navigation-GPS

by M. Aoyama (6 March 1994)

Navigation, ship position and velocity over the ground was provided throughout the cruise by a Magnavox MX4400 GPS receiver. Throughout the cruise, the positioning was based on the WGS-84 and in 3-D mode. Since we could get 4 satellites throughout the cruise, the HDOP was ranged from 1 to 2. Positions were logged in port Marakal at the start and the end of the cruise and a rms position error are as follows;

Pre-Cruise;

Mean position at Marakal harbor, Palau: 7-19.831N, 134-27.482E

Rms position error: N-S: 19 meters    E-W: 29 meters

Post-Cruise;

Mean position at Marakal harbor, Palau: 7-19.???N, 134-27.???E

Rms position error: N-S: ?? meters    E-W: ?? meters

### b. Echosounding

by M. Aoyama (22 April 1994)

The water depth obtained by the multi-narrow beam echo sounder (General Instrument) and by using the CTD observation and altimeter equipped to CTD are summarized in Table 7-1. The differences are less than +/- 0.5 % at the most stations, while the differences increased up to 4 % at the stations at steep topography.

Table 7-1. The differences between water depth estimated summing of CTD observation plus altimeter reading and uncorrected echosounding depth.

Station number	CTD plus altimeter meter	echosounding (uncorrected) meter	Diff. meter
6N 1	3188	3180	-8
6N 2	4129	4133	4
6N 3	3751	3798	47
6N 4	4017	4026	9
6N 5	4862	4852	-10
6N 6	5278	5258	-20
6N 7	5561	5539	-22
6N 8	5568	5541	-27
6N 9	5494	5470	-24
6N 10	5580	5567	-13
6N 11	5327	5349	22
6N 12	4642	4654	12
6N 13	5572	5547	-25
6N 15	3787	3782	-5
24 1	5370	5270	-100
24 2	5677	5733	57
24 3	6430	6390	-40
24 4	3987	4031	44
24 6	3172	3178	6
24 7	2479	2475	-4
24 8	2884	3003	119
24 9	2033	2060	27
24 11	3474	3483	9
24 12	3571	3551	-20
24 14	3488	3489	1
24 15	4163	4175	12
24 16	3408	3430	22
24 17	3594	3640	46

24	19	4735	4727	-8
24	20	4266	4270	4
1S	1	1473	1526	53
1S	2	3006	3020	14
1S	4	4114	4124	10
1S	6	4394	4395	1
1S	8	3996	4003	7
1S	9	3128	3120	-8
1S	11	4500	4508	8
1S	12	4712	4707	-5
1S	13	4816	4856	40
1S	15	5035	5031	-4
1S	16	5462	5436	-26
1S	17	5479	5456	-23
1S	18	5546	5516	-30
1S	19	5549	5521	-28
1S	20	5542	5514	-28
1S	21	5672	5636	-36

---

## 8. CTD/Rosette hardware

by K. Ando and M. Aoyama (6 March 1994)

### (1) CTD/rosette systems

The 12-liters 36-positions intelligent GO rosette (GO1016) water sampler with SBE9plus CTD for 10,500 meters (primary CTD/rosette system) was used on the sections of 6N,PR24 and PR1S. The sensors attached on the CTD were two temperature sensors, two conductivity sensors, one DO sensor, one pressure sensor and two altimeter sensors. The CTD and 36 position rosette were mounted within a stainless frame of dimension 1.7 m height x 2.2 meter diameter. The weight of the package in the air is 800 Kg when the 36 bottles of 12 liters are full. Thirteen to seventeen of the rosette bottles were fitted with the set of two SIS digital reversing thermometers and one SIS digital reversing pressure meter. The wire was a single conductor 10.6 mm steel rope manufactures by Rochester cables, and the winch was built by Tsurumi Seiki Japan. Since our winch was not of traction winch design nor jumble sheave design, we reduce the bottles from 36 to 30-24 when the swell became up to 2 to 2.5 meters for the safety operation.

After a cast the rosette was pushed forward on a railway about 6 meters in the shelter that is modified standard sea carrier container with air conditioned and all sampling was performed there. Subsequently digital instruments were read and the TC sensors was cleaned by Triton-X detergent, fresh water and pure water at each cast.

The 5 liters 12-positions rosette water sampler with SBE9plus CTD for 6,800 meters (secondary CTD system) was used on the line of TM to save the ship-time.

The sensors used attached on the primary CTD system and the secondary CTD system are listed in (a) and (b).

#### (a) The sensors of the primary CTD system

The sensors used are listed below.

Primary temperature sensor	: Model SBE3 for 10,500 meters S/N 031462
Primary conductivity sensor	: Model SBE4 for 10,500 meters S/N 041045
Pump for primary sensor pair	: Model SBE5 for 10,500 meters S/N 050846

Secondary temperature sensor : Model SBE3 for 10,500 meters  
S/N 031465  
Secondary conductivity sensor : Model SBE4 for 10,500 meters  
S/N 041174  
Pump for secondary sensor pair: Model SBE5 for 10,500 meters  
S/N 050847

Pressure sensor : Digiquarts pressure sensor  
for 10,500 meters  
S/N 41223  
Primary Altimeter : Benthos model 2110-1 for 12,000 meters  
S/N 199  
Secondary Altimeter : DATASONIC PSA-900A for 6,000 meters  
S/N 396  
Dissolved Oxygen sensor : Model SBE13 for 10,500 meters  
S/N 130311

The calibrations of temperature, conductivity and pressure sensors were conducted by NRCC in October 1993. The drift of temperature and conductivity sensors are reported in Chapter 11.

Sensor performances during this cruise :

The differences of two sensors for temperature and conductivity are shown in Figure 8-1. Though the calculation of these differences are performed by using the raw data under 500 meters, the maximum differences are within 0.001 C in temperature sensors and within 0.0002 S/m in conductivity sensors.

(b) The secondary CTD system

The sensors used are listed below.

Primary temperature sensor : Model SBE3 for 6,800 meters  
S/N 031207  
Primary conductivity sensor : Model SBE4 for 6,800 meters  
S/N 040960  
Pump for primary sensor pair : Model SBE5

S/N 050484

Secondary temperature sensor : Model SBE3 for 6,800 meters  
S/N 031523

Secondary conductivity sensor : Model SBE4 for 6,800 meters  
S/N 041148

Pump for secondary sensor pair: Model SBE5  
S/N 050863

Pressure sensor : Digiquarts pressure sensor  
for 6,885 meters  
S/N 43435

Altimeter : DATASONIC PSA-900A for 6,000 meters  
S/N 396

Dissolved Oxygen sensor : Model SBE13 for 6,800 meters  
S/N 130257

During the cast, we used the 32 of reversing thermometers (SIS RTM) and 17 of reversing pressuremeters (SIS RPM). 5 of 32 RTM were broken during the cruise. Since 8 of RTM were varied much and 2 of RTM began to drift, we basically adapted the data of stable 17 RTM data. Since one RPM (RPM 10055) showed larger difference of 20 dbar, we do not refer to the data of RPM 10055. A comparison result of CTD and RTM temperature and RPM pressure below 4000 dbar is given in Table 8-1.

Table 8-1 Summary of RTM and RPM data. Average (upper row) and Standard deviation (lower row).

---

Range dbar	CTD-RTM	CTD-RPM
7600 - 4998	0.003	-1.1
	0.001	2.5
6001 - 4998	0.003	-1.1
	0.001	2.6
5003 - 3996	0.004	-0.4
	0.002	1.8

---

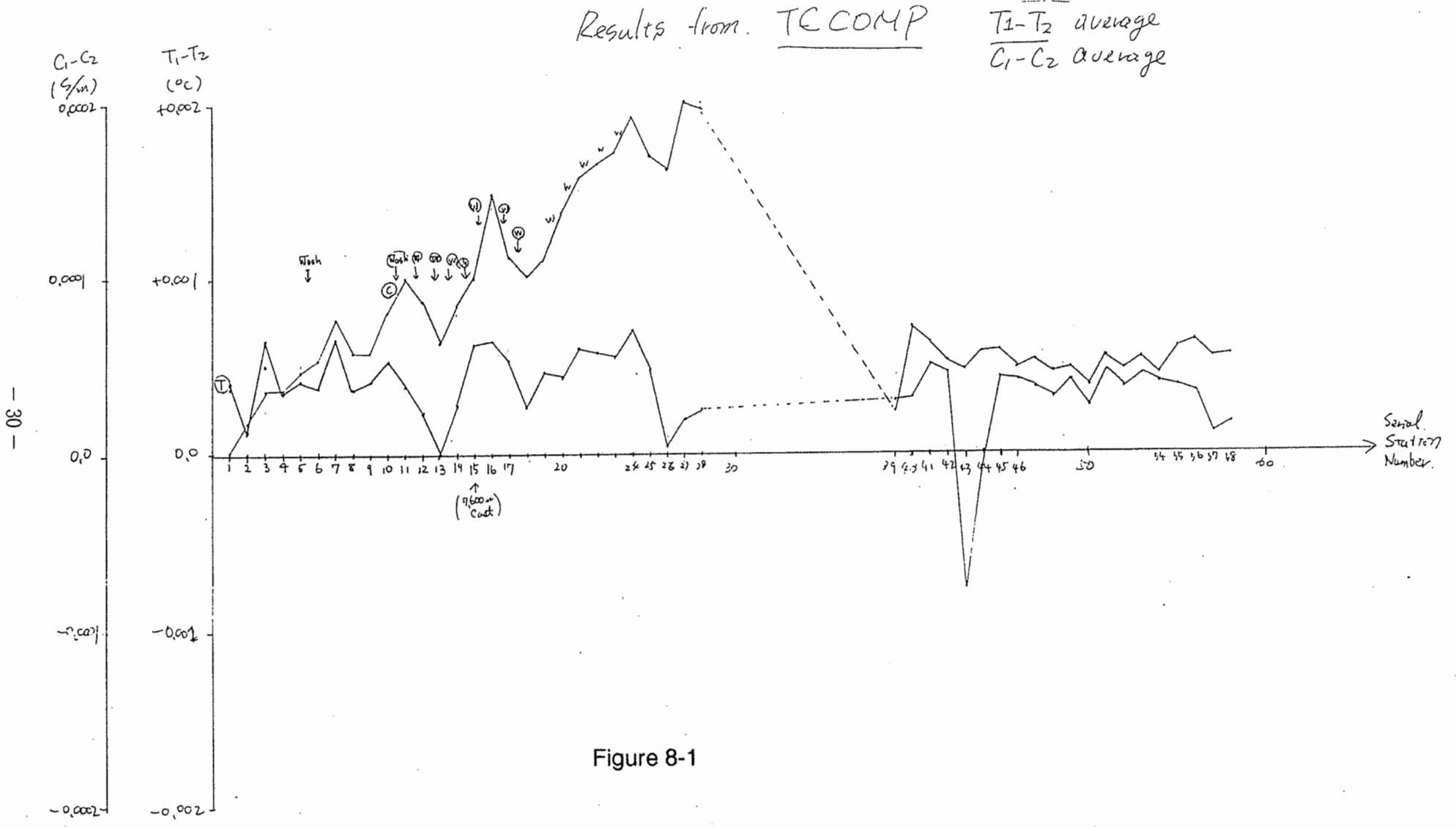

Figure 8-1

## 9. Moorings

by Kentaro Ando (JAMSTEC) for ADCP and CTD

Hidetoshi Watanabe (STM) for current meters

Atsuo Ito (NME) for mooring system ( 3 March 1994)

Here we describe the deployment of two moorings and the recovery of two moorings between Talaud-Morotai Islands. The deployments of two moorings have successfully finished, but the recovery of two moorings have failed.

### (a) DEPLOYMENT OF MOORING BETWEEN TALAUD AND MOROTAI ISLAND

The purpose of these moorings is to estimate the seasonal change of the volume transport between Talaud and Morotai islands with comparisons with the results of numerical simulation.

The Indonesian through flow is an inter-ocean current between Pacific Ocean and Indian Ocean, which is continued to the Atlantic Ocean (Gordon(1983)). The estimation of the net volume flux between Pacific Ocean and Indian Ocean have been performed for many years, using the historical data analysis and numerical simulations. Recently, Masumoto and Yamagata (1993) shows the seasonal variability of baroclinic ocean circulation around the Indonesian islands from the results of their numerical-simulated ocean. They shows the large amplitude seasonal transport around the Indonesian islands.

For the measurement of seasonal current variation between Talaud and Morotai island, two moorings were deployed at 04-01.239N, 127-30.634E on February 21, and 03-10.793N, 128-27.367E on February 22 in the strait between Talaud and Morotai Island (see Figure 9-1 and 9-2). These moorings are named Talaud-Morotai North (TMN) and Talaud-Morotai South (TMS). Each mooring has one upward self-contained broad-band ADCP (150KHz) at 250 meters depth, one CTD (SBE16) at 260 meters depth and three Aanderaa current meters at 350 meters, 550 meters and 1,050 meters depth. The mooring lines are shown in Figure 9-3 and 9-4.

The parameters set in each instrument are listed below.

ADCP : R&D instrument 150 KHz Self-contained Broad-band ADCP

Serial number : 1153 for TMN

1152 for TMS

Beam angle : 30 degree

Beam direction: Upward

Sampling layer: 0 - 248 meters in every 8 meters

Sampling interval : 1 hour

Ping per ensemble : 16 pings

Intervals in each pings : 2 seconds

CTD : SBE 16 with depth sensor

Serial number : 1282 for TMN

1283 for TMS

Sampling interval : 30 minutes

Current meters

: Aanderaa current meter model RCM-4 & RCM-5

Serial Number : 8306 for TMN 350 meters depth

4267 for TMN 550 meters depth

4557 for TMN 1,050 meters depth

8277 for TMS 350 meters depth

8637 for TMS 550 meters depth

4272 for TMS 1,050 meters depth

Interval : 60 minutes

Record device : IC memory

Releaser

: Benthos Model 865A-DB

Serial Number : 633 for TMN

666 for TMS

: Nichiyu

Serial Number : 4232 for TMN

4237 for TMS

In these mooring lines, we use two releasers for each line.

We hope the mooring lines would be released and recovered successfully after one year mooring.

(B) EFFORTS OF RECOVERY AND DEPLOYMENT OF MARK BUOY

The two moorings deployed between Talaud and Morotai Islands in October 1992 cruise ( Chief Scientist : Kei Muneyama, PI: Takiwaki and Watanabe) were scheduled to be recovered during this cruise. Unfortunately, these two moorings could not be recovered during this cruise.

On February 21, we tried to recover the mooring at 03-27.44N, 127-52.96E. The releaser responded and returned the release signals to us. But the buoys did not appear on the sea surface. The depth of the releaser did not change at all. Having no equipment to recover the mooring line from sea bottom, we deployed the marker buoy for the recovery of a next chance near the mooring line.

On February 22, the other mooring at 03-12.22N 128-26.89E was not released, neither. The situation of this mooring is the same as that on February 21. We also deployed the marker buoy. Figure 9-5 shows the mark buoys deployed near these two un-recovered moorings.

188° 20' M

188° 20' M

191° 20' M

189° 20' M

188°

04-01.078N  
127-30.757E

04-00.743N  
127-30.743E

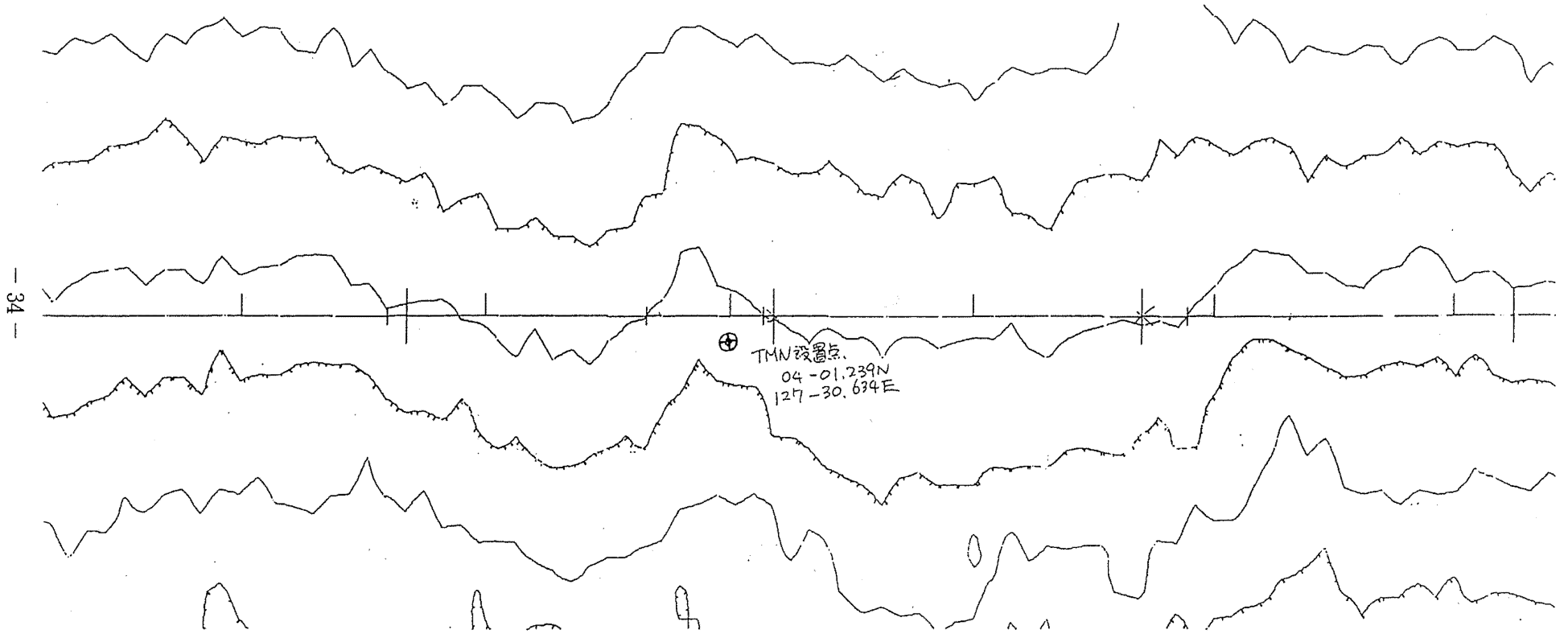

Figure 9-1

2581

2580

2580

2580



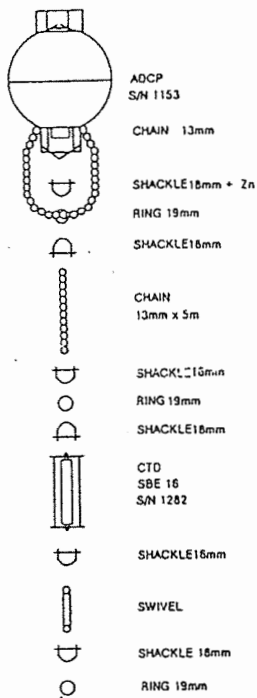

ADCP  
S/N 1153

CHAIN 13mm

SHACKLE 18mm + Zn

RING 19mm

SHACKLE 18mm

CHAIN 13mm x 5m

SHACKLE 18mm

RING 19mm

SHACKLE 18mm

CTD  
SBE 16  
S/N 1282

SHACKLE 18mm

SWIVEL

SHACKLE 18mm

RING 19mm

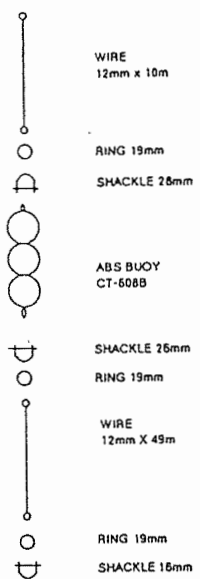

WIRE  
12mm x 10m

RING 19mm

SHACKLE 28mm

ABS BUOY  
CT-608B

SHACKLE 28mm

RING 19mm

WIRE  
12mm X 49m

RING 19mm

SHACKLE 18mm

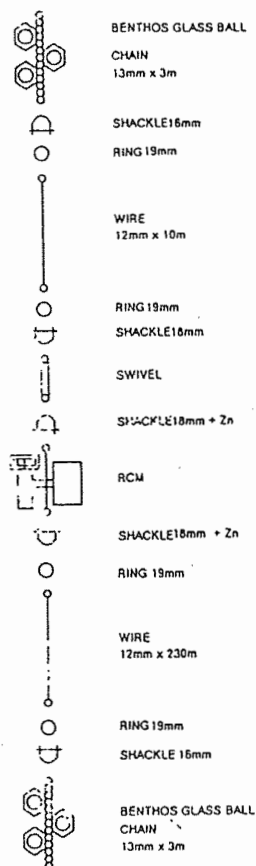

BENTHOS GLASS BALL

CHAIN  
13mm x 3m

SHACKLE 18mm

RING 19mm

WIRE  
12mm x 10m

RING 19mm

SHACKLE 18mm

SWIVEL

SHACKLE 18mm + Zn

RCM

SHACKLE 18mm + Zn

RING 19mm

WIRE  
12mm x 230m

RING 19mm

SHACKLE 18mm

BENTHOS GLASS BALL

CHAIN  
13mm x 3m

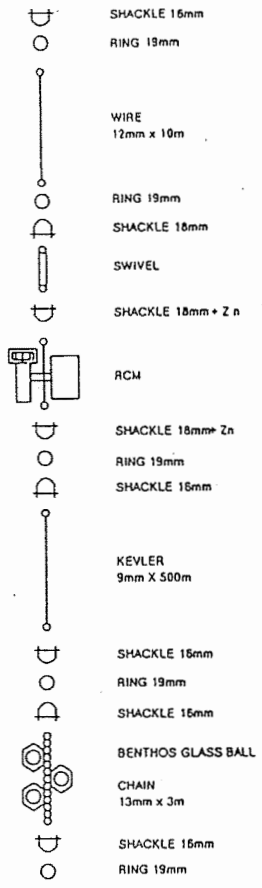

SHACKLE 18mm

RING 19mm

WIRE  
12mm x 10m

RING 19mm

SHACKLE 18mm

SWIVEL

SHACKLE 18mm + Zn

RCM

SHACKLE 18mm + Zn

RING 19mm

SHACKLE 18mm

KEVLAR  
9mm X 500m

SHACKLE 18mm

RING 19mm

SHACKLE 18mm

BENTHOS GLASS BALL

CHAIN  
13mm x 3m

SHACKLE 18mm

RING 19mm

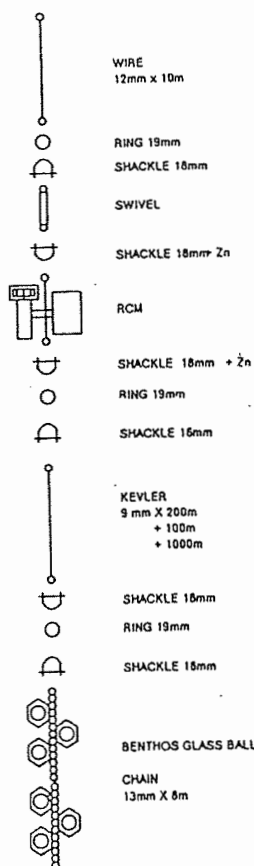

WIRE  
12mm x 10m

RING 19mm

SHACKLE 18mm

SWIVEL

SHACKLE 18mm + Zn

RCM

SHACKLE 18mm + Zn

RING 19mm

SHACKLE 18mm

KEVLAR  
9 mm X 200m  
+ 100m  
+ 1000m

SHACKLE 18mm

RING 19mm

SHACKLE 18mm

BENTHOS GLASS BALL

CHAIN  
13mm X 8m

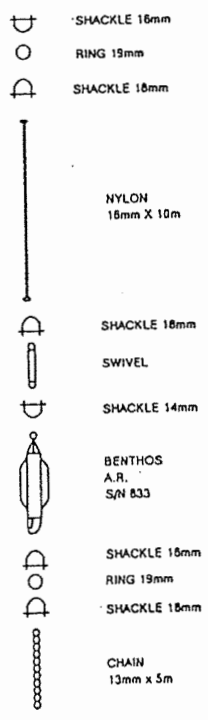

SHACKLE 18mm

RING 19mm

SHACKLE 18mm

NYLON  
18mm X 10m

SHACKLE 18mm

SWIVEL

SHACKLE 14mm

BENTHOS  
A.R.  
S/N 833

SHACKLE 18mm

RING 19mm

SHACKLE 18mm

CHAIN  
13mm x 5m

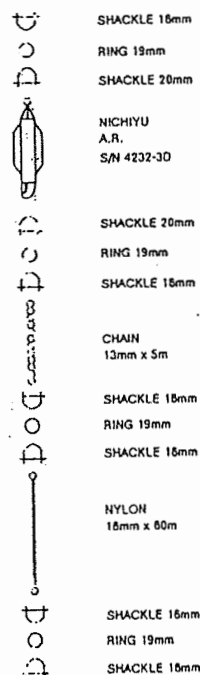

SHACKLE 18mm

RING 19mm

SHACKLE 20mm

NICHYU  
A.R.  
S/N 4232-3D

SHACKLE 20mm

RING 19mm

SHACKLE 18mm

CHAIN  
13mm x 5m

SHACKLE 18mm

RING 19mm

SHACKLE 18mm

NYLON  
18mm x 80m

SHACKLE 18mm

RING 19mm

SHACKLE 18mm

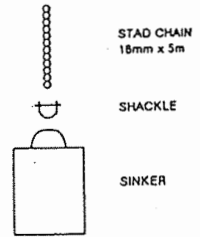

STAD CHAIN  
18mm x 5m

SHACKLE

SINKER

Figure 9-3

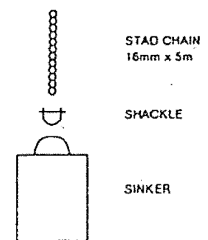
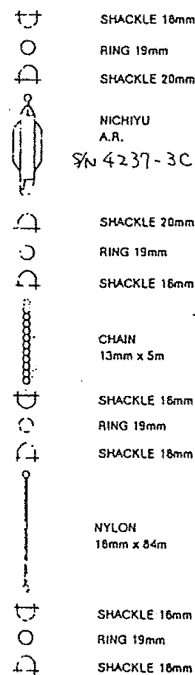
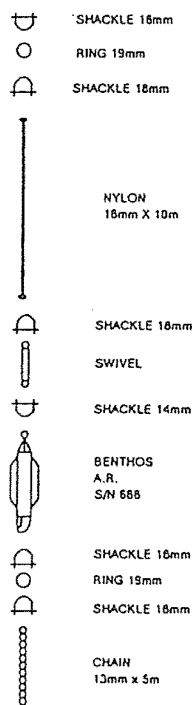
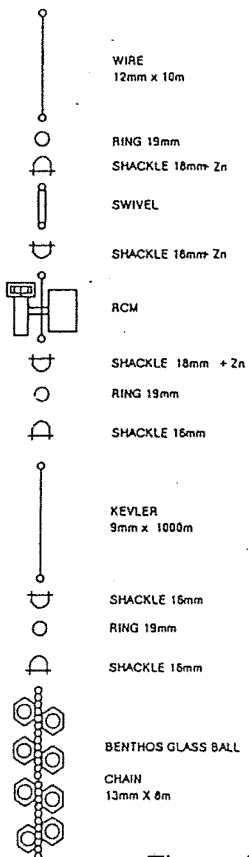
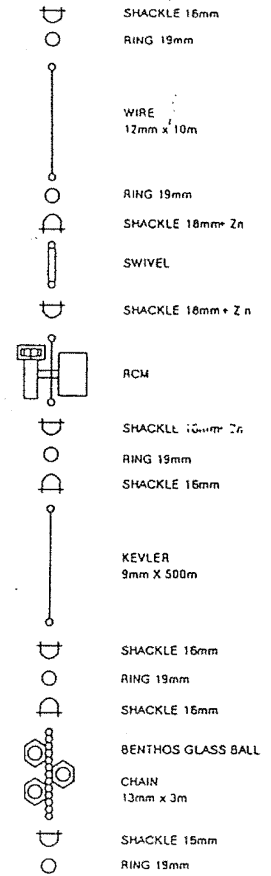
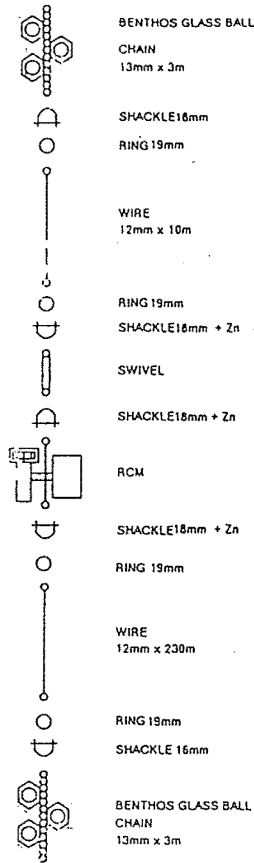
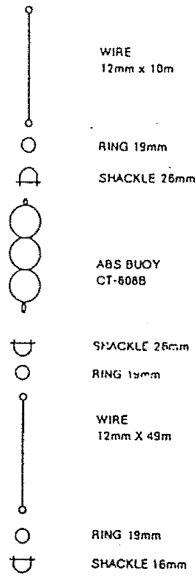
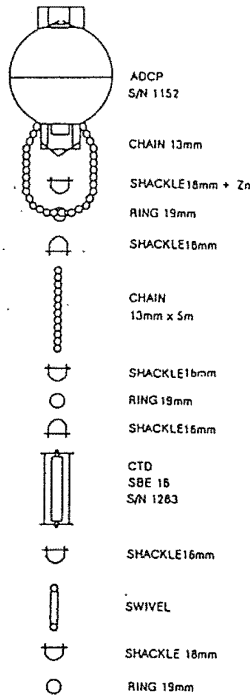

Figure 9-4

MARK-1&2



BENTHOS GLASS BALL

CHAIN  
13mm x 5m



BENTHOS  
A.R.  
S/N 630 - First  
S/N 632 - Second



CHAIN  
13mm x 1m

NYLON  
16mm x 50m

NYLON  
16 mm x 10m

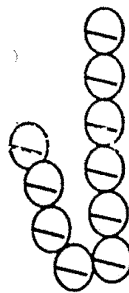

SCLAP CHAIN  
ABOUT 100kg

Figure 9-5

## 10. CTD/ Rossete operation

by SYAEFUDIN (3 March 1994)

WOCE'94 Cruise using two kinds of CTD/Rosettes, the big rosette and the small rosette. The big rosette is General Oceanic 1016 equipped with a 36 position Niskin bottles (12 l volume) and CTD Sea-Bird Electronics Inc. model SBE 9/11 plus CTD system, 15,000 Psi Pressure and 10,500 depth used in track lines 6N, PR 24 and PR1S. The small rosette is General Oceanic 1015 equipped with a 12 position Niskin bottles (5 l volume) and CTD Sea-Bird Electronics Inc. model SBE 9/11 plus CTD system, 10,000 Psi Pressure and 6,800 depth, only used in the track line PR24-2. Some Niskin bottles of both rosettes are equipped with RPM and RTM to measure pressure and temperature in the depth which we want.

Drive rosette out from container and check some bolts on the frame and Niskin bottles and than send HOME command from CR (Control Room) to the Rosette Setting Man (RSM) on deck. HOME command is mean the position of firing bottles equipment is located between bottle number one and the last bottle (No. 12 for small rosette and no. 36 for big rosette).

How to make HOME command in CR ??? are as follows :

C> SS4200> SEASAVE and return/enter..... (SEASAVE in dir. SS4200)

Display on screen .....

- SEASAVE Main Menu
- Display Archived Data
- Display Real-Time Data
- Serial Out put Setup

before running the PC please choose Serial Output Setup and press return/enter if you want to modify (in this cast output ASCII data = No)

Press Esc to exit editing and go to Main Menu...and choose Display archived Data and press Enter/Return to Select the Option which you want.....press Esc to Quit and go to Main Menu.

Choose Display Real-Time Data Set Up and press Enter/return to Modify..

In this Cast :

Store Data on Disk = Yes

Data File Path = C: WOCE94

Data File Name = Line.No. Cast.DAT.

Config File Path = C: SS4031

Config File [.CON]=10000AL2.CON

Display File [.DSP]=WOCE depth.DSP

Legend:

depth : depend on station depth

File name : Down Cast and Up Cast

and than press F10 to Acquire Real-Time Data and send XHOME Command to RSM on deck.

After that We setup Niskin Bottles from no.1 to 36 (or 12 for small), check cocks of Niskin bottles must be closed and than setup RPM/RTM (Check battery) and write S/N , offset of RPM on the log book. Make disconnected the tube from the bottom of T-Sensor. Tell to CR Rosette ready to deployment !!!!!!!!!!!!!

Control tension meter, winch speed, wire out length and CTD pressure during operation. On the 10 m depth from sea level , winch stop for a moment and Winch Man (WM) report wire out length, tension to CR operator. CR operator write those data on the CTD Operation Log Book (COLB) and watch the graphic display of temperature , Dissolved oxygen (DO) on screen (P.C) are those O.K. and than replay to WM with CTD pressure . Winch continued to go out with speed 0.5 m/s and WM tell wire out length, tension and winch speed to CR operator each 100 m depth reached 500 m. In the heavy condition (if sea water not quit) WM tell CR operator range of the tension meter. after reached 200 m increase winch speed to 0.75 m/s or 1.0 m/s if rang of CTD pressure and wire out length not large (approximately 30 - 50).

After reached 500 m depth increase winch speed to 1.5 m/s (CR operator must watches the CTD descent rate on screen). WM tell CR operator each 500 m depth and CR operator replay.

At the 300 m above sea bottom (estimated from sounding data and CTD pressure ) the altimeter was read (Userpoly 1) in the status line exchanged CTD Deck Control Unit became channel 6 and tell WM to decrease winch

speed to 0.5 m/s (better step by step command to winch speed be came 0.5 m/s). At the 50 m to the sea bottom Winch stopped for a moment to check altimeter reading. Winch continued to within 10 m - 20 m (if flat sea bottom topography) and 50 m- 100 m (in heavy condition and sea bottom not flat) and CR operator told CTD in that condition (xx meters to the sea bottom, CTD pressure) to WM and Bridge.

Checked Down Cast file exist or not, Press F1 (exit), Esc answer YES and Press enter/return to make Up Cast File and than press F10 to Acquire Real-Time Data. Firing bottom sampling bottle number 1 and 2 , and winch continued go up to next sampling layer wich you want. At the 10 meters before sampling layer CR operator told WM to decrease Winch ters to the sea bottom, CTD pressure) to WM and Bridge.

Checked Down Cast file exist or not, Press F1 (exit), Esc answer YES and Press enter/return to make Up Cast File and than press F10 to Acquire Real-Time Data. Firing bottom sampling bottle number 1 and 2 , and winch continued go up to next sampling layer wich you want. At the 10 meters before sampling layer CR operator told WM to decrease Winch speed to 0.5 m/s and on firing bottle equipped with RPM/RTM please wait 1 minutes.

After finished all of bottles and CTD on deck press Control F1 to exit Acquire Real-Time Data and turn off CTD Deck Unit.

# 11. CTD data processing

by Y. Kashino ( 22 April 1994)

## Introduction

The CTD data was acquired by SBE 911 plus system whose frequency was 24 Hz. This data was calibrated as much as possible on board and converted to WOCE-format CTD file. SEASOFT provided by Sea-Bird Electronics Inc. and some programs developed in JAMSTEC were used on this procedure. The programs developed in JAMSTEC were coded in FORTRAN. (Microsoft FORTRAN compiler was used). We used SEASOFT ver. 4.200 except for SEASAVE. SEASAVE Ver. 4.031 was used because SEASAVE ver. 4.200 had a bug.

Although we have twin T and C sensors for CTD system, we report only the result of primary sensor. We used the result of secondary sensor to check up one of primary sensor. Although we have DO-sensor, we don't report the result because we haven't established calibration method of DO-sensor.

We don't also report the data when CTD was near surface (upper than 15 db) because the pump of CTD was not active then.

Pre-cruise and post-cruise calibration for temperature and conductivity sensors were carried out at NRCC (Northwest Regional Calibration Center) in U.S.A. on 28 September 1993 and 26 March 1994. Post-cruise calibration for pressure sensor by dead weight tester was carried out at JAMSTEC on 21 April 1994. We check up and calibrated CTD data considering these result except for one of post-cruise calibration for conductivity sensor. The reason why we didn't consider the result of conductivity sensor calibration was that it showed that its drift was too large and the value in Philippine basin calibrated by this result didn't agree with the values by Autosal on this cruise and value of historical data.

### a. Seagoing computer

We used 3 computer systems for data processing as follows (Fig.11-1):

(1) System 1 (for data acquisition)

CPU: DECpc 466D2LP (IBM compatible computer)

with 8MB memory, 240MB hard disk and 3.5-inch floppy disk drive.  
Optical disk: 3.5-inch and 5-inch optical disk drives.

We used 3.5-inch optical disk during data processing and 5-inch optical disk for backup of raw data from deck unit.

Other: This system is connected with deck unit.

(2) System 2 (for data processing)

CPU: DECpc 466D2LP

with 8MB memory, 240Mb hard disk, 3.5-inch floppy disk drive and 5-inch floppy disk drive.

Optical disk: 3.5-inch optical disk drive.

Plotter: Hewlett Packard 7475A Plotter (Paper size is A4)

Other: This system was connected with VAX station 4000 by LAN.

(3) System 3 (for data editing)

CPU: Hewlett Packard Vectra 386/20N (IBM compatible computer)

with 4MB memory, 52MB hard disk and 3.5-inch floppy disk drive.

Optical disk: 3.5-inch optical disk drive.

b. Data processing

(1) General

In order to remove noise in raw temperature, conductivity and pressure data, we developed software that replaced noise data by running mean. We defined the noise as shown in table 11-1. The result (also in table 11-1) is shown that there were few noises over criteria shown in table 11-1.

(Temperature and conductivity data had no noise !!)

When CTD decent rate becomes slow or reversal because of the pitch of the ship, water around rosette will go down faster than CTD and will be mixed with water being measured by CTD. This is called "shed wake" and will make error (See the part III of Chap. 18). We have developed program that finds shed wakes when CTD decent rate is less than 0.25 m/s and linearly interpolates pressure, temperature and conductivity values in the shed wake using its upper and lower values. If the number of the interpolated values is more than half of the number of observations in some 2db pressure bin, its quality flags of pressure, temperature and salinity should be 6 in CTD file.

After all on-board calibration, uniform pressure CTD profile data was created by same method as one of Millard and Yang (1992).

## (2) Temperature

The results of laboratory calibrations for temperature sensors show that CTD temperature sensor tend to drift constantly with time (See Chap. 18). The difference between twin temperature sensors was almost constant (See Chap. 5). According to result of post-cruise calibration carried out on 26 March, drift of the temperature sensor was +0.0025 (deg C). Considering these result, we could estimate that offset correction added to the value of primary temperature sensor was +0.0020 (deg C) during this cruise.

Laboratory calibration executed on IPTS-68 unit, we converted raw temperature value on IPTS-68 to ITS-90 unit using formula (3) of Millard and Yang (1992) after the offset correction.

## (3) Conductivity(salinity)

Conductivity value was corrected as follows:

### Step 1. Sensor response correction.

Millard and Yang (1992) says that the sensor response correction between temperature and conductivity data should be done for Mark IIIb CTD and the lag is from 0.10 to 0.45 seconds. We checked how long time lag between T and C sensors is for SBE 911 plus system. We determined time lag at the time when total salinity spike area was minimum. Total salinity spike area S is

$$S = \sum_{i=1}^N (P_{Li} - P_{Ui}) H_i.$$

N is the number of spike, P is pressure, H is height of spike and suffix U and L mean upper and lower boundary of spike. Fig. 11-2 is result at casts 6N-02, and PR1S-18. The results show that time lag should be 0.8 steps, that is, 0.033 seconds. We used ALIGNCTD of SEASOFT for correction throughout this cruise.

### Step 2. Cell thermal mass correction.

Sea-Bird Electronics Inc. recommend that conductivity cell thermal mass effect should be removed. We used CELLTM of SEASOFT to remove this effect.

This utility uses recursive filter determined in Lueck (1990).

### Step 3. Cell factor correction.

We used Autosal to calibrate CTD conductivity sensor. We determined cell factor by linear regression between CTD conductivity when bottle was fired and conductivity of sampled water measured by Autosal for every casts. CTD conductivity was corrected using the equation as follows:

$$C_{\text{calibrated}} = A \times C_{\text{raw}} + B.$$

A and B are slope and offset respectively.

### Step 4. For salinity spike

Even if sensor response correction is done, the salinity spikes still remain. When we find a salinity spike larger than 0.01 PSU in some 2db pressure bin, quality flag of salinity should be 3 in CTD file.

### (4) Pressure

Raw data from pressure sensor has short period oscillation (Fig.11-3). We used FILTER of SEASOFT and filtered this oscillation by low pass filter that time constant was 0.15 seconds.

The correction of pressure value for deck pressure was not carried out because deck pressure of our CTD was less than +/-0.4db during observation. (Fig. 11-4)

The result of post-cruise calibration by dead weight tester are shown in Fig. 11-5. This shows that the residual between CTD pressure and pressure by dead weight tester is less than 0.7 db and hysteresis is 0.2 db. We don't correct this small residual.

### c. Data flow

(See Fig. 11-6)

(1) SEASAVE (SEASOFT)

Acquires, displays and saves raw data from deck unit to disk. On this cruise data was stored in hard disk. We will use RAM disk for device saved raw data on next WOCE cruise.

(2) DATCNV (SEASOFT)

Converts raw, binary data output by SEASAVE to ASCII format data written on physical unit. When water is sampled, this program can output data to .ROS file from that time to some time. (On this cruise, this interval was 10 seconds.)

(3) ROSSUM (SEASOFT)

Edits .ROS file output by DATCNV and writes out a summary file to .BTL file.

(4) TCCOMP (Made in JAMSTEC)

Compares values of primary and secondary sensors and plots histograms for check of sensor performance.

(5) SPLIT (SEASOFT)

Divides data into upcast data and downcast data. We used this utility to acquire only downcast data for save of disk space.

(6) NOISE (Made in JAMSTEC)

Finds noise data and replace it by running mean. This program can remove unnecessary surface data.

(7) ALIGNCTD (SEASOFT)

Corrects time lag between temperature sensor and conductivity sensor for minimizing salinity spiking error.

(8) FILTER (SEASOFT)

Uses low pass filter to remove short period oscillation in pressure data.

(9) CELLTM (SEASOFT)

Correct conductivity cell thermal effect using a recursive filter.

(10) FDSHDWK (Made in JAMSTEC)

Finds shed wake and interpolates data using the values of its upper and lower boundary.

(11) FSPIKE (Made in JAMSTEC)

Finds salinity spike.

(12) CALBC (Made in JAMSTEC)

Calibrates conductivity data by cell factor correction.

(13) AVGDAT (Made in JAMSTEC)

Calculates 2db pressure averaged data.

(14) MKCTD (Made in JAMSTEC)

Creates WOCE-CTD file.

d. Conclusion

We could acquire high quality CTD data satisfying WOCE requirement except for the bin where salinity spikes and shed wakes were. The accuracies of pressure, temperature and salinity were as follows:

Pressure : 1 db

Temperature: 0.001 deg C

Salinity: 0.002 PSU (from 500m to 2000m depth)

0.001 PSU (deeper than 2000m depth)

Problems remain as follows:

(1) According to Millard and Yang (1992), time lag between temperature and conductivity sensors depends on CTD velocity. We haven't tested this point and used some constant value for time lag.

(2) Accuracy of parameters was not good when shed wakes appeared. We should think how to operate the CTD/Rosette not to make shed wakes.

References

Millard,R. and K.Yang, 1992, CTD calibration and processing methods used by Woods Hole Oceanographic Institution, Draft (April 20, 1992)

Lueck,R.G., 1990, Thermal inertia of conductivity cells: Theory., American Meteorological Society, 741-755,

Table 11.1. Definition of noise and the number of noise detected by this definition.

	Pressure (db)	Temperature (deg C)	Conductivity (S/m)
Noise definition			
1. Range	0.5 < or 8000 >	0 < or 32 >	2 < or 8 >
2. Difference from previous step value	1.0 >	0.5 >	0.05 >
3. Difference from running mean			
(a) 0 - 400m	0.5 >	1.0 >	0.1 >
(b) 400 - 1000m	0.5 >	0.2 >	0.02 >
(c) 1000 - 2000m	0.5 >	0.1 >	0.01 >
(d) 2000m -	0.5 >	0.05 >	0.005 >
The number of noise	97	0	0

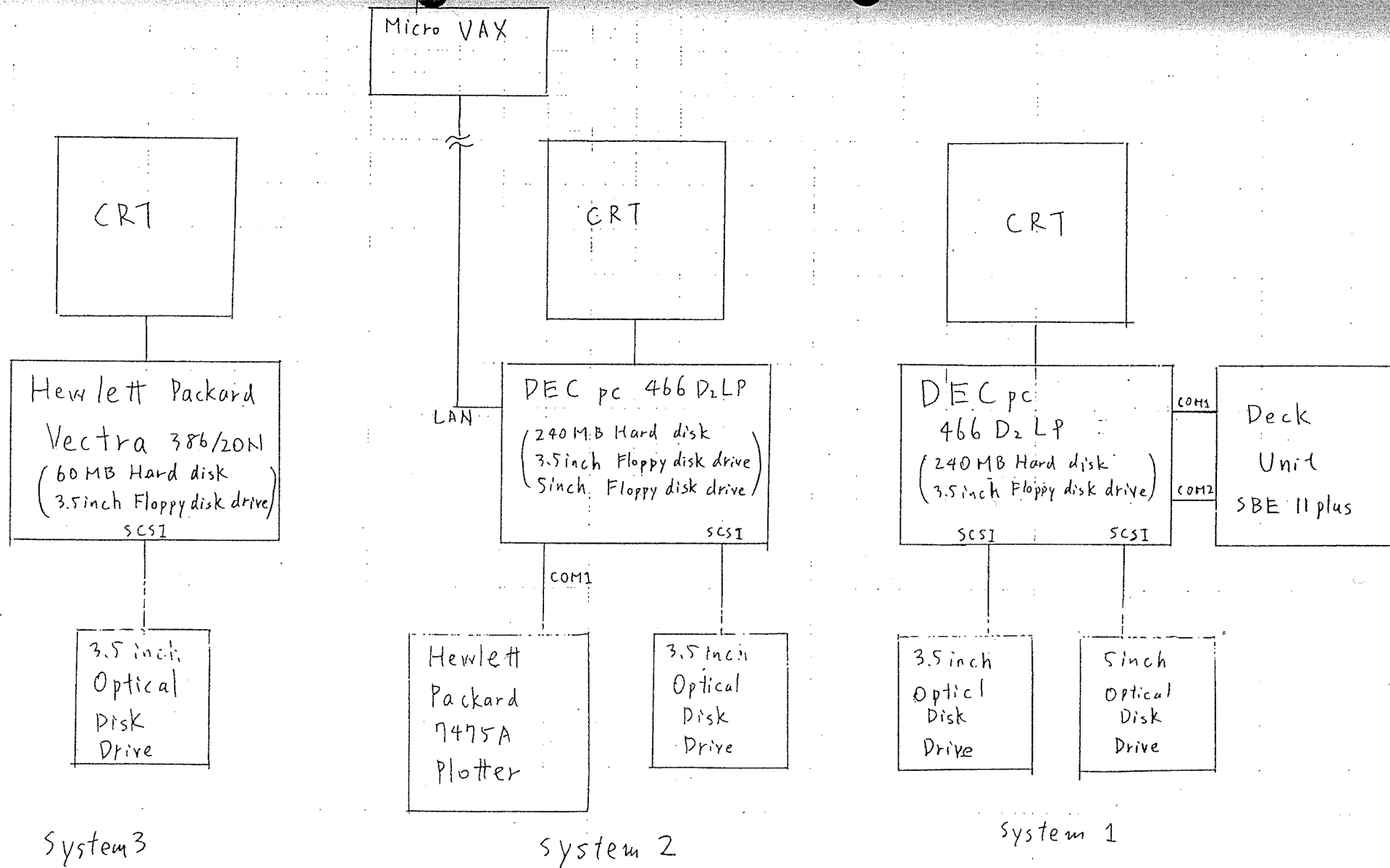

Figure 11-1 Computer systems for CTD data processing

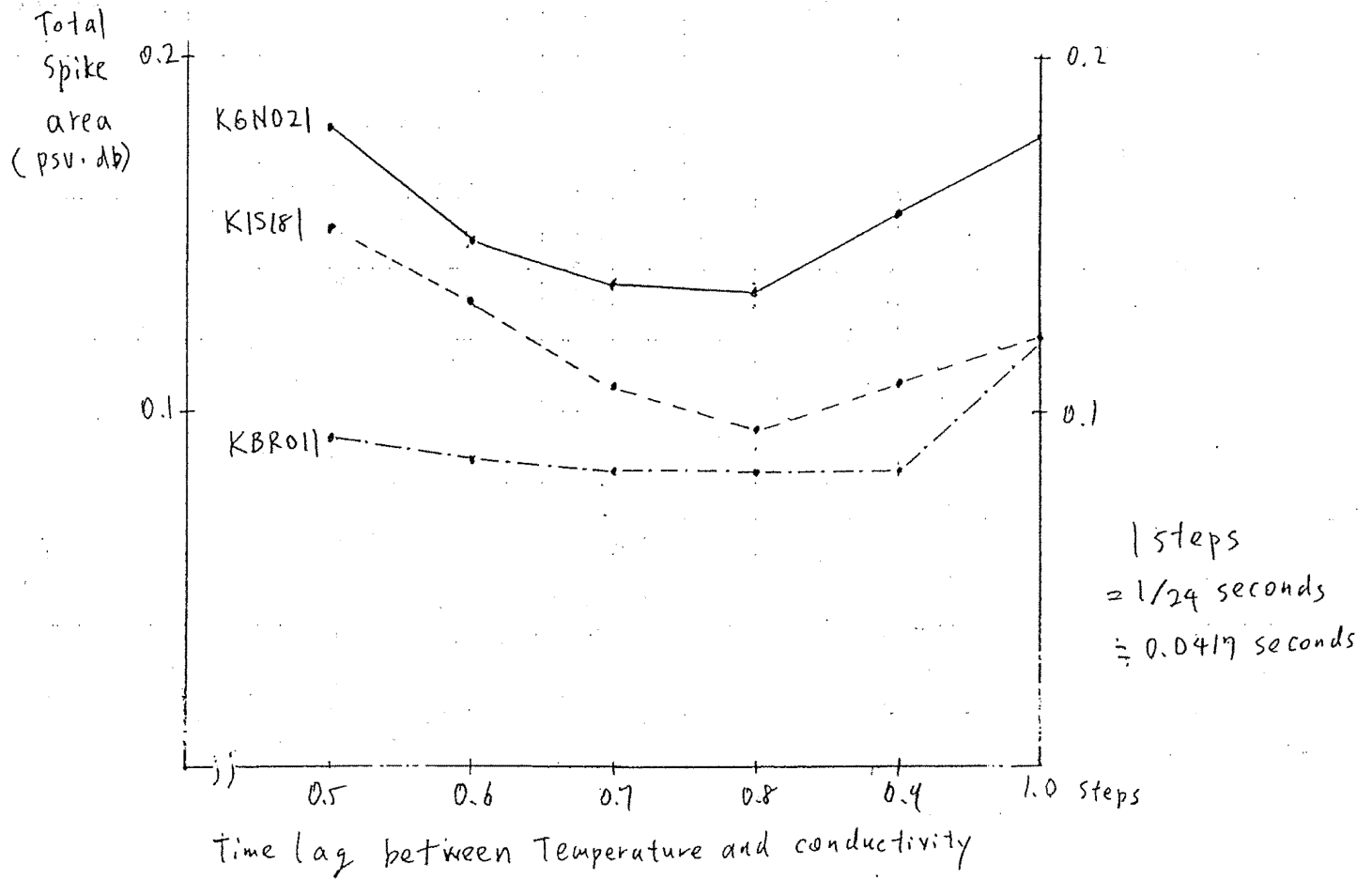
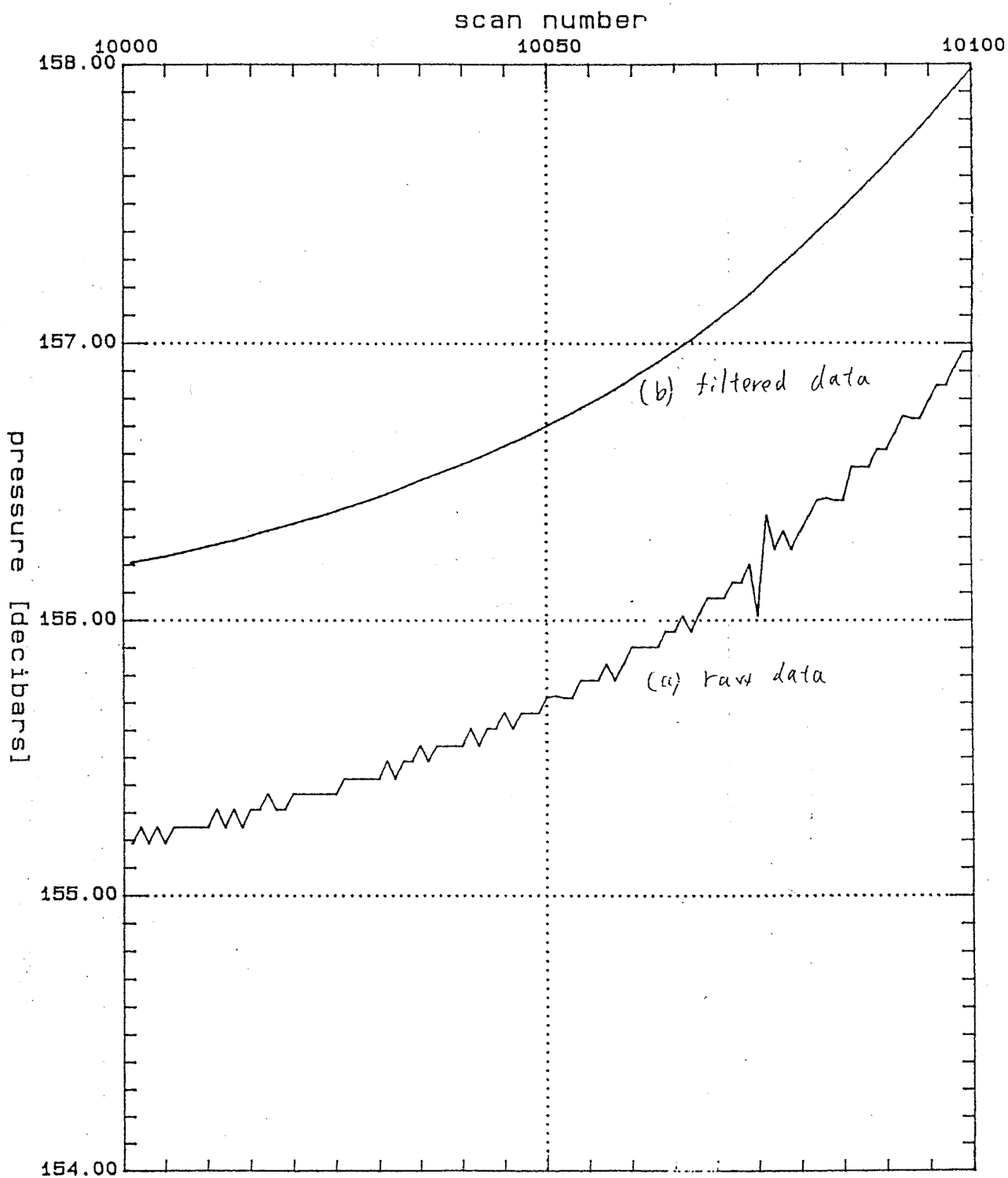

Figure 11-2 Total salinity spike area variability for time lag between Temperature and conductivity at casts K6N021, K15181 and KBRO11



KBR011RM.CNV: KBR011

Figure 11-3 Pressure variability (a) raw data, (b) filtered data by low pass filter. Pressure value of filtered data is added by 2 db.

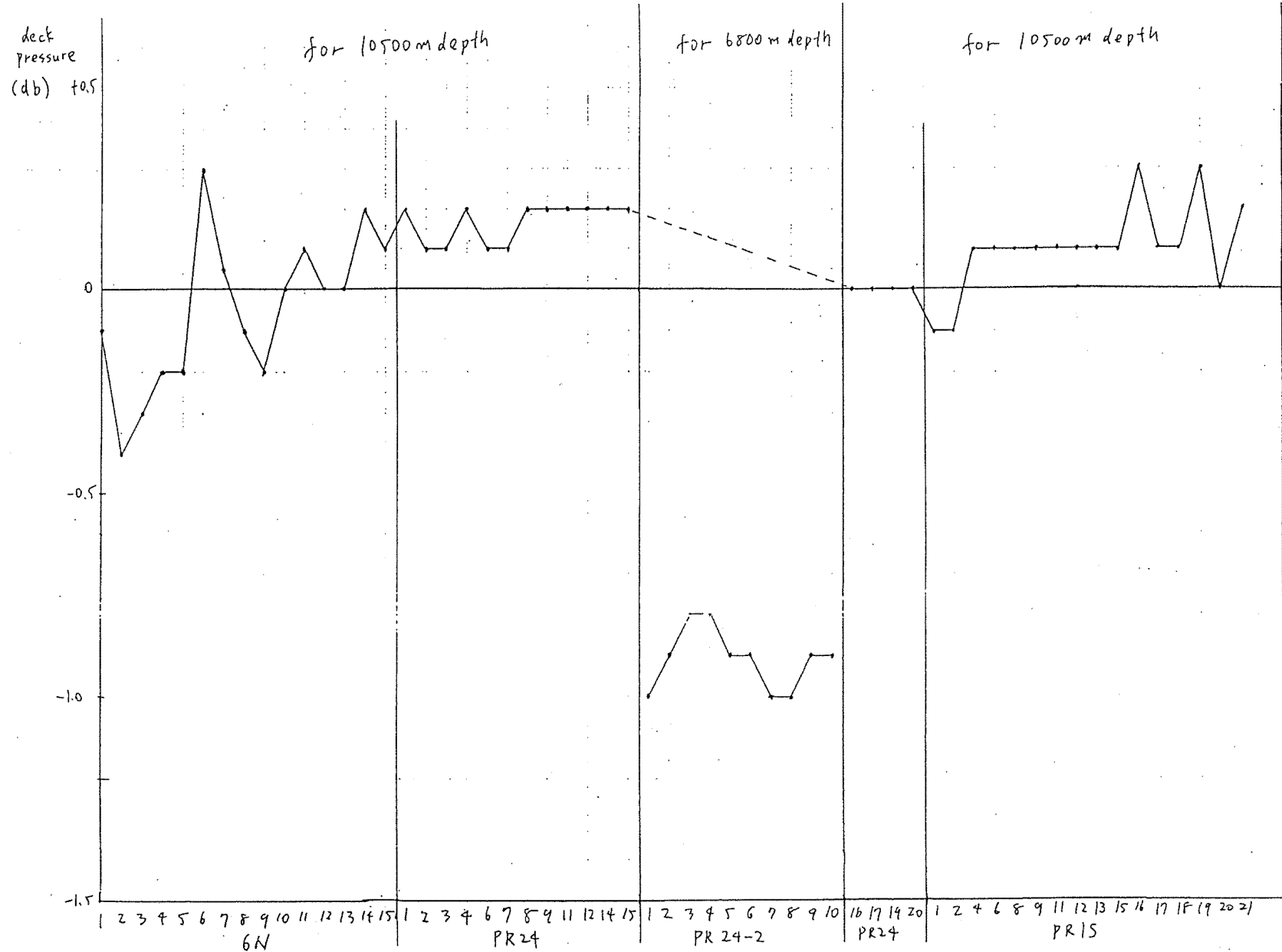
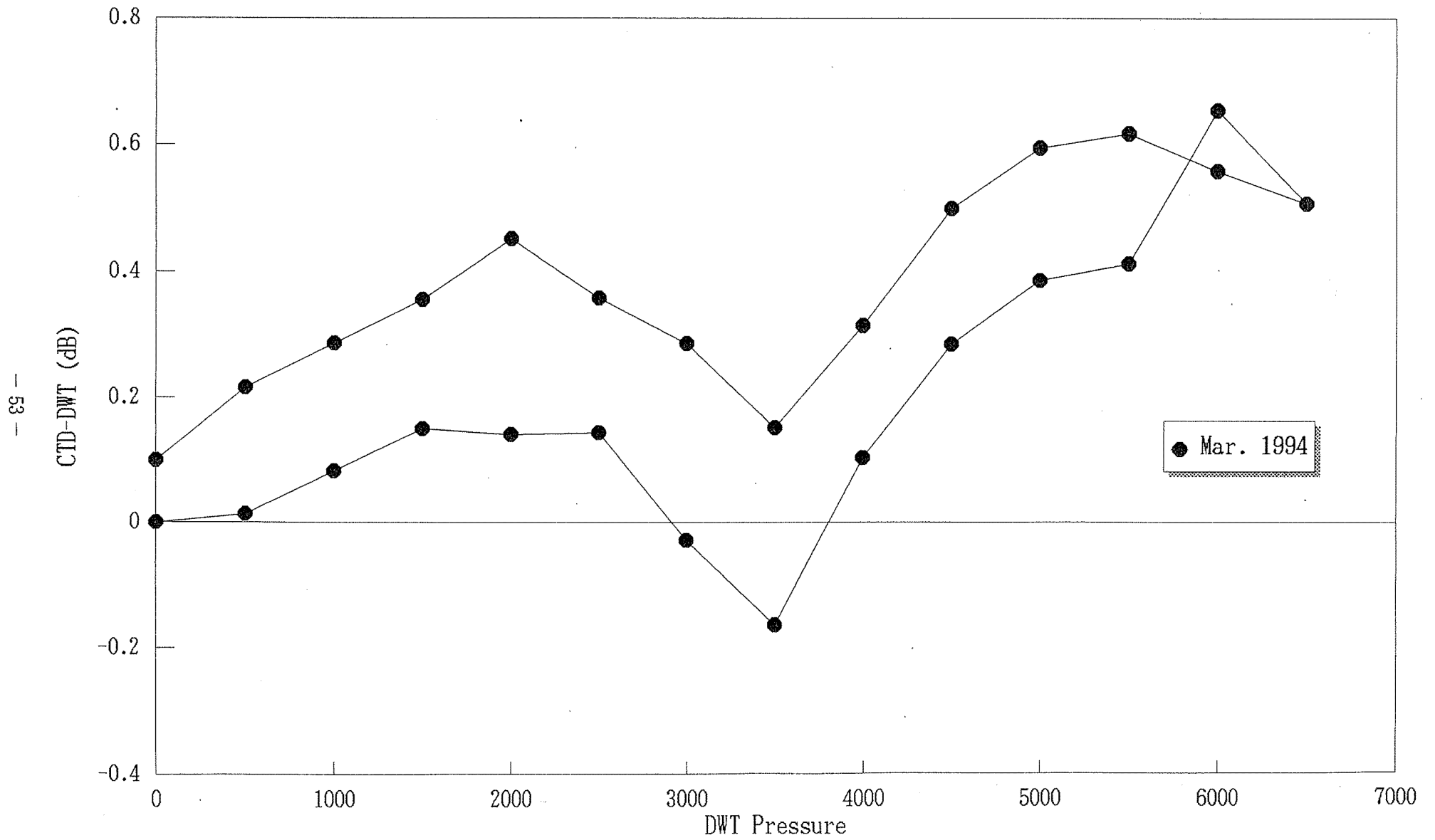

Figure 11-4 Variability of deck pressure

Fig.11-5 Calibration of Pressure Sensor



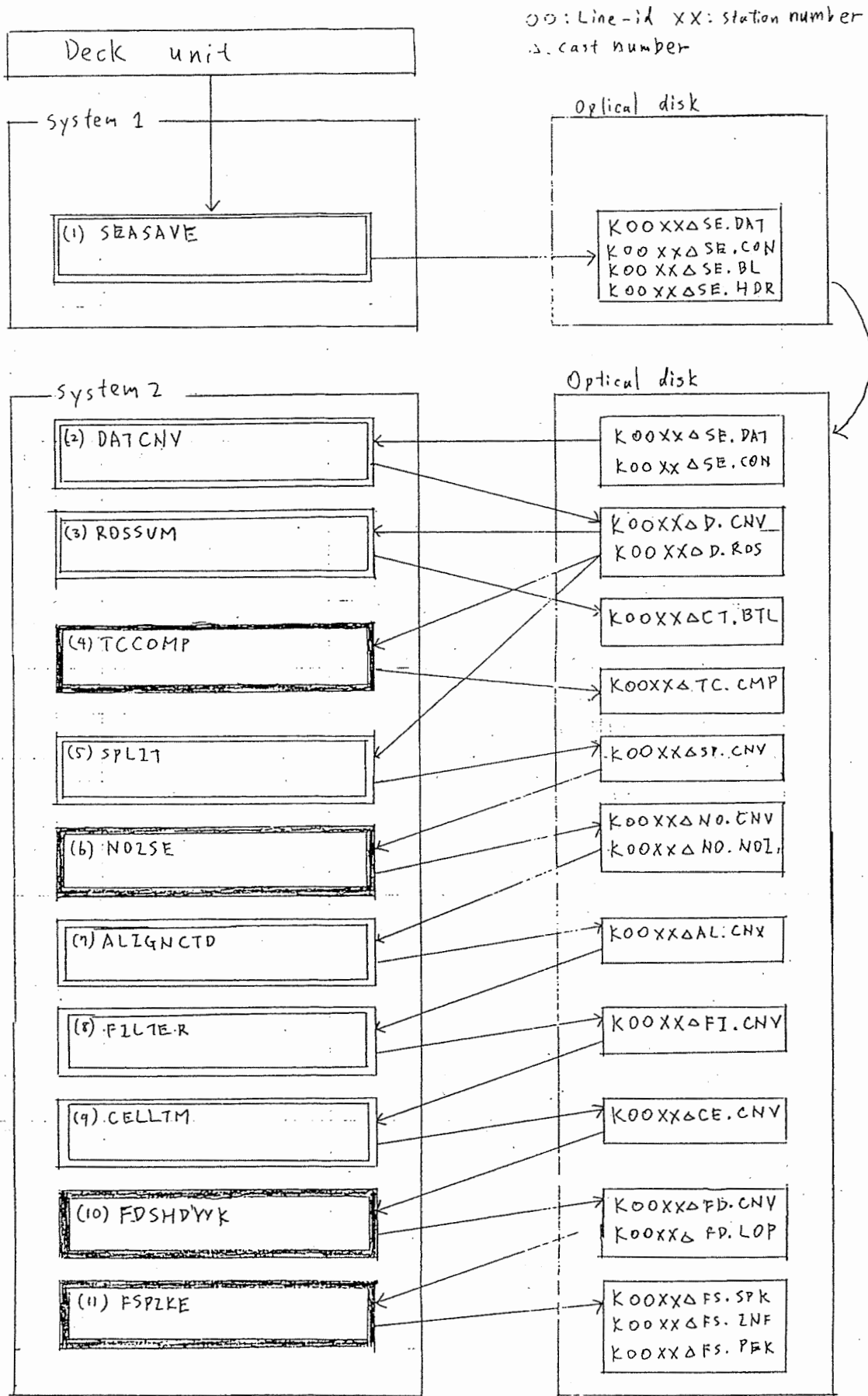
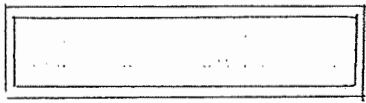
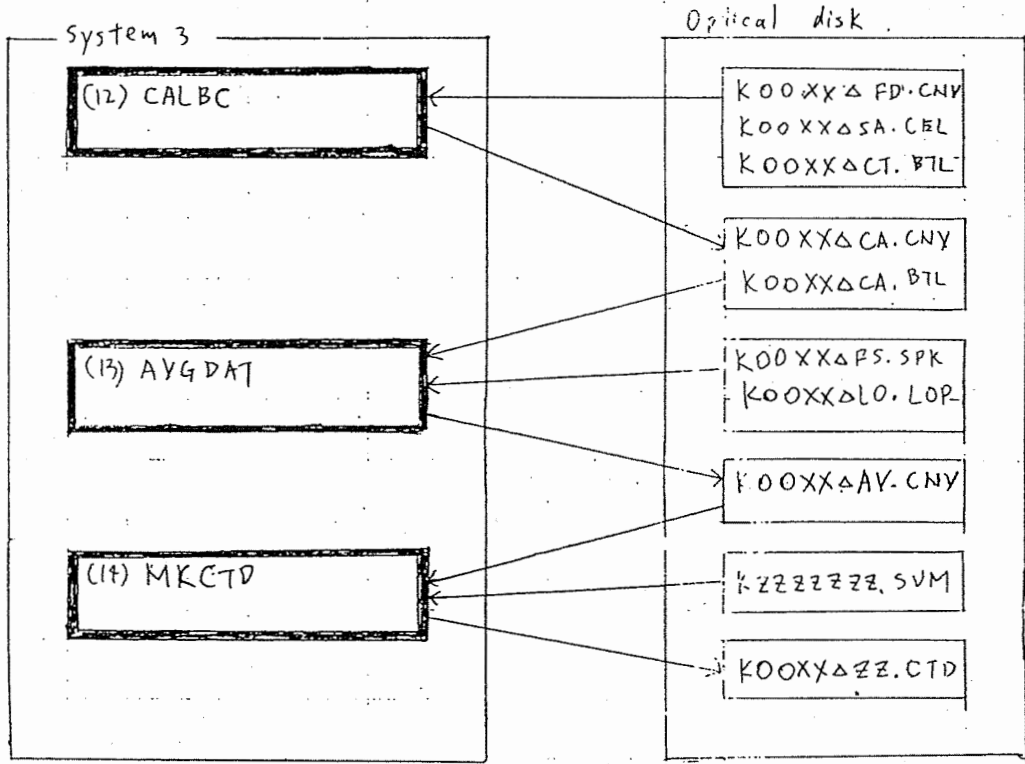
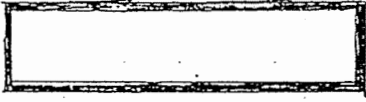

Figure 11-6 Data flow of CTD data processing



: Program of SEASOFT



: Program developed in JAMSTEC

- .DAT : Raw data from deck unit (Binary)
  - .CNY : Temporary file outputed by utilities (ASCII)
  - .BTL ) Data file when water is sampled
  - .ROS
  - .CMP
  - .NOZ
  - .SPK
  - .INF
  - .PKK
  - .LOP
- ) Information file
- .SUM : WOCE-SUM file
  - .CTD : WOCE-CTD file

Figure 11-6 (continued)

## 12. Sample water salinity measurements

by T. Kawano, K. Takao, A. Ito (22 April 1994)

### a. Salinity Sample Bottles

The bottles in which the salinity samples are collected and stored are 250 ml Phoenix brown glass bottles with screw caps. We checked the integrity of same type bottles (125 ml) by following method.

- 1) fill bottles with pure water and screwed caps
- 2) keep bottles approx. 1 deg C for 12 hours
- 3) then keep bottles approx. 35 deg C for 12 hours

The volume change of pure water was less than 0.01 ml. This result suggests that the salinity change by evaporation should be less than 0.001 practical salinity unit (PSU) in case of 250 ml bottles.

### b. Salinity Sample Collection and Temperature Equilibration

Each bottle was rinsed three times with sample water and was filled to the shoulder of the bottle. The caps was also thoroughly rinsed. Salinity samples were stored for about 24 hours in the same laboratory as the salinity measurement was made.

### c. Instrument and Method

The salinity analysis was carried out by two Guildline Autosol salinometer model 8400B, which were modified by addition of an Ocean Science International peristaltic-type sample intake pump and a Hewlett Packard quartz thermometer model 2804A with two 18111A quartz probes. One probes measured an ambient temperature and another probe measured a bath temperature. The resolution of the quartz thermometer was set to 0.001 deg C. Data of both the salinometer and the thermometer was collected simultaneously by a personal computer. A double conductivity ratio was defined as a median of 31 readings of the salinometer. Data collection was started after 5 seconds and it took about 10 seconds to collect 31 readings by a personal computer.

Two salinometers were operated in the air-conditioned ship's laboratory at a bath temperature of 24 deg C. An ambient temperature varied from approximately 22 deg C to 25 deg C, while a variation of a bath temperature was almost within +/- 0.001 deg C.

#### d. Standardization

Standardization was effected by use of 92 ampoules of IAPSO Standard Seawater batch P123 whose conductivity ratio was 0.99994. Standardization was made five times during the cruise. Summary is listed on Table 12-1. Four of 92 ampoules were evidently of too high salinity and four of these were dubious. These eight were not used as standards. A standard deviation of these 84 ampoules was about 0.0003 PSU.

#### e. Sub-Standard Seawater

We also used sub-standard seawater which was deep-sea water filtered by pore size of 0.45 micrometer and stored in a 20 liter cubitainer made of polyethylene and stirred for at least 24 hours before measuring. It was measured every six samples in order to check and correct the trend. We measured 403 sub-standards and nine of which were dubious. A standard deviation of the remaining 394 sub-standards was approximately 0.0004 PSU.

#### f. Replicate and Duplicate Samples

There were 47 pairs of replicate and duplicate samples drawn. We used two types of rosette bottles and they were tripped at the bottom of every station. One is a Niskin bottle equipped with an ordinary rubber tube and another is that equipped with Teflon coated stainless spring. We drawn two samples from the bottle with the rubber tube as a replicate sample and one sample from the bottle with the spring as a duplicate sample. All pairs of both replicate and duplicate samples were from bellow 1450 m depth. There were two bad measurements of replicate samples and there were also two bad measurements of duplicate samples. Excluding these bad measurements, the standard deviation of 45 pairs of replicate samples was 0.0005 PSU and that of 45 pairs of duplicate samples was 0.0006 PSU. This results shows, as well as our precision of measurements, that concerning about salinity there was no difference between the bottle equipped with the rubber tube and that equipped with Teflon coated stainless spring.

#### g. Cell-Factors

Cell-factors were calculated at each station by a linear regression

analysis using conductivity data below 700 m depth. Slopes and offsets are listed on Table 12-2.

Table 12-1 Summary of Standardization

---

Autosal No.	Standardize control	No. of Ampoule	Mean of 2Rt	Station
1	718	13	1.99981	6N01 - 6N06
2	431	6	1.99990	6N07
2	419	12	1.99983	6N08 - 6N14
2	425	33	1.99987	6N15 - PR24-15
1	728	28	1.99989	PR24-16 - PR1S-21

---

Mean of 2Rt --- Mean of double conductivity ratio

Table 12-2 Cell-factors

Station	Slope	Offset
6N-1	1.00041509	-0.00134506
6N-2	1.00048037	-0.00157996
6N-3	1.00053153	-0.00175232
6N-4	1.00045526	-0.00151759
6N-5	1.00023839	-0.00087788
6N-6	1.00040020	-0.00141283
6N-7	1.00015178	-0.00047281
6N-8	0.99990921	+0.00030041
6N-9	1.00058658	-0.00189294
6N-10	1.00067006	-0.00221524
6N-11	1.00023847	-0.00078544
6N-12	1.00014831	-0.00049095
6N-13	1.00046808	-0.00150333
6N-14	1.00046262	-0.00146277
6N-15	1.00045962	-0.00145261
PR24-1	1.00055720	-0.00177583
PR24-2	1.00023161	-0.00074566
PR24-3	1.00047907	-0.00154018
PR24-4	1.00024580	-0.00070473
PR24-6	1.00100610	-0.00314476
PR24-7	1.00002916	-0.00003811
PR24-8	1.00054847	-0.00164449
PR24-9	1.00044089	-0.00127227
PR24-11	1.00055051	-0.00170839
PR24-12	1.00017876	-0.00054066
PR24-14	1.00044016	-0.00140412
PR24-15	1.00016521	-0.00051373
PR24-16	1.00010761	-0.00036839
PR24-17	1.00055353	-0.00180407
PR24-19	1.00078538	-0.00249294
PR24-20	1.00053539	-0.00168593
PR1S-1*	1.00007889	-0.00015122
PR1S-2	1.00037540	-0.00117401

PR1S-4	1.00025666	-0.00075317
PR1S-6	1.00067952	-0.00213944
PR1S-8	1.00054777	-0.00173303
PR1S-9	1.00081087	-0.00251449
PR1S-11	1.00062591	-0.00196514
PR1S-12	1.00049917	-0.00145260
PR1S-13	1.00004944	-0.00004653
PR1S-15	1.00058576	-0.00173603
PR1S-16	1.00043451	-0.00129345
PR1S-17	1.00064930	-0.00198615
PR1S-18	1.00056519	-0.00173534
PR1S-19	1.00033201	-0.00096688
PR1S-20	1.00055058	-0.00168770
PR1S-21	1.00051912	-0.00155780

---

\* Using conductivity data below 300m depth

### 13. Dissolved Oxygen determination

by A. SONODA, M. Aoki, R. Takeo and T. Shiribiki ( 22 April 1994)

#### Methods:

Oxygen samples were collected from Niskin bottles to calibrated dry glass bottles, and overflow it with 3 bottle volumes of sample water. The sub-sampling bottle consists of the ordinary BOD flask(ca. 200 ml) and glass stopper with long nipples that modified Green and Carritt(1966).

Sample were fixed dissolved oxygen immediately following the water temperature at the time of collection was measured for correction of the sample density.

The samples were analyzed ca. 2 hours later. The samples was determined by Metrohm piston buret of 10 ml with Pt electrode using whole bottle titration in the laboratory controlled temperature (ca. 20 deg. C).

The standardization did everyday and whenever change to new reagents. An analytical method was fundamentally done according to the WHP Operations and Methods (Culberson,1991).

End point was evaluated by the second-derivative curve method with computerization.

#### Instrument:

Titration ; Metrohm Model 716 DMS Titrino/10 ml of titration vessel  
Pt Electrode/6.0401.100

Software ; Data acquisition / Metrohm,METRODATA/6.6013.000  
Endpoint evaluation / it was written in N88BASIC/MS-DOS(NEC/PC9801nc)

#### Reproducibility:

14 % of total samples was analyzed as replicates taken from same bottle. And, in the bottom layer at many stations, duplicates was analyzed. In addition, at PR24-16 and 1S-01, different bottles fired at same depth, and duplicates was analyzed.

Replicates from 227 pairs of samples were obtained a standard deviation(2 sigma) of 0.96 umol/Kg(0.46% of D.O. maximum in this cruise). Duplicates from 43 pairs of the bottom layer samples taken from different bottles ( # 1 and 2) fired at the same depth had a mean difference of 0.41 umol/Kg, and standard deviation(2 sigma) of 1.2 umol/Kg(0.55% of D.O. maximum in this

cruise). And 8 samples of station PR24-16 from 3249 m was obtained average of 147.9  $\mu\text{mol/Kg}$ , and standard deviation(2 sigma) of 0.98  $\mu\text{mol/Kg}$ ( 0.66%),while 16 samples of station 1S-01 from 301 m was obtained average of 141.4  $\mu\text{mol/Kg}$ , and standard deviation(2 sigma) of 0.34  $\mu\text{mol/Kg}$ ( 0.24%). The results from duplicates of Niskin bottle #1 and #2 were indicated that the values of #2 is smaller in comparison with the values of # 1. However, to the end of this cruise, these differences became it gradually small.

#### Blank Determination:

The pure water blanks were determined in distilled water (Milli-RX12, Millipore). The result of the pure water blanks were obtained average of 0.0020 ml, and standard deviation of 0.0010 ml.

The amount of dissolved oxygen in the reagents was reported 0.0017 ml at 25.5 deg. C (Murray et al.,1968). In our laboratory onboard ship, however room temperature was controlled at 18 - 21 deg.C. Therefore it was determined for this cruise. Consequently, it was obtained the amount of 0.0027 ml at 21 deg. C.

We could obtained 142 samples for seawater blank in this cruise. Seawater blank were measured at surface, the oxygen minimum and bottom layer of many station.

On the other hand, seawater blank were analyzed from all Niskin bottles at the station TM-10 and 1S-21. Vertical profiles of seawater blank were not significantly varied with depth. But it was suggested that were not conservative.

In this cruise, seawater blank was obtained average of 0.94  $\mu\text{mol/Kg}$ , and standard deviation ( 2 sigma ) of 0.72  $\mu\text{mol/Kg}$ . The precision was only obtained  $0.75 \pm 0.28$   $\mu\text{mol/Kg}$  ( n=5 ) at one time. It was suggested that seawater blank varied with each sample. But we could not determined at each depth that oxygen samples are taken in this cruise. Therefore we used average value (=0.94) for calculation of dissolved oxygen concentrations.

#### Thiosulfate Standardization:

Measurement of standardization were used thiosulfate of 1 batch,4 bottles and standards of 2 batch,18 bottles(#1 of 15 bottles,#2 of 3 bottles) in this cruise(about one month). The results of standardization was obtained average of 0.7230 ml, and standard deviation of 0.0027 ml (0.37%). It was

suggested that reagents probably were influenced by laboratory temperature.

Comparison of standards from different institution:

Except the KIO3 standard solution, we used the titration system and reagents of Scripps Institution of Oceanography, Oceanographic Data Facility (SIO/ODF).

We show the result to the following table.

Table 13-1. Comparison of standards from JAMSTEC and SIO.

Institution	Nominal normality	KIO3 dispensed	Avg. titer	STD	Rasio to SIO/ODF
SIO/ODF	0.0100102	9.9928	0.49527	0.00004	1.00000
JAMSTEC1	0.0100200	9.9921	0.49581	0.00011	1.00018
JAMSTEC2	0.0100200	9.9930	0.49544	0.00012	0.99934
CSK	0.0100	9.9924	0.49458	0.00010	0.99967
Blank			-0.00039	0.00020	

References:

Culberson, C. H.(1991) Dissolved Oxygen,in WHP Operations and Methods, Woods Hole., pp.1-15.

Culberson, C. H., G. Knapp, R. T. Williams and F. Zemlyak (1991) A comparison of methods for the determination of dissolved oxygen in seawater(WHPO 91-2), Woods Hole.

Horibe,Y., Y. Kodama and K. Shigehara (1972) Errors in sampling pocedure for the of dissolved oxygen by Winkler method,J.Oceanogr.Soc.Jpn., 28, 203-206.

Green, E. J. and D. E. Carritt (1966) An Improved Iodine Determination Flask for Whole-bottle Titrations, Analyst, 91, 207-208.

Murray, N., J. P. Riley and T. R. S. Wilson (1968) The solubility of oxygen in Winkler reagents used for the determination of dissolved oxygen, Deep-Sea Res., 15, 237-238.

# 14. Nutrients measurements

by K. Komine, H. Ota, K. Nakao and M. Aoyama ( 22 April 1994)

## a. Equipment and techniques

The nutrients analyses were performed on Bran+Luebbe continuous flow analytical system Model TRAACS 800 (4 channels). The manifolds for the analysis are shown in Fig. 14-1,14-2, 14-3 and 14-4 for the Nitrate+nitrite, nitrite, silicate and phosphate, respectively. TRAACS 800 was located in the container laboratory on deck the R/V Kaiyo. The laboratory temperature was maintained between 22-24 deg C.

The methods used were as follows:

### 1st channel

Nitrate+Nitrite: Nitrate in seawater is reduced to nitrite when a sample is run through a cadmium tube (1 mm diameter, 10 cm length) inside of which is coated with metallic copper. The nitrite produced is determined by diazotizing with sulfanilamide and coupling with N-1-naphthyl-ethylenediamine (NED) to form a colored azo dye which is measured spectrophotometrically at 550 nm using 3 cm length cell. Nitrite initially present in the sample is corrected.

### 2nd channel

Nitrite: The nitrite is determined by diazotizing with sulfanilamide and coupling with N-1-naphthyl- ethylenediamine (NED) to form a colored azo dye which is measured spectrophotometrically at 550 nm using 5 cm length cell.

### 3rd channel

Silicate: The standard AAll molybdate-ascorbic acid method with the addition of a 38-40 C heating bath to reduce the reproducibility problems encountered when analyzing samples at different temperatures. The silicomolybdate produced is measured spectrophotometrically at 630 nm using 3 cm length cell.

### 4th channel

Phosphate: The method of Murphy and Riley (1962) was used, but separate additions of ascorbic acid and mixed molybdate-sulfuric acid-tartrate and addition of a 38-40 deg C heating bath. The phosphomolybdate produced is measured spectrophotometrically at 880 nm using 5 cm length cell.

#### b. Sampling Procedures

Sampling for nutrients followed that for oxygen and C-14. Samples were drawn into polypropylene 100 ml small mouth bottles. These were rinsed two to three times before filling. Most of the samples were then analyzed 3 to 5 hours after collection. Samples were stored in a refrigerator at 8 degree C when the TRAACS 800 was not available for rapid analysis after collection. Polystylen 4 ml sample cups and glass 3 ml sample cups were used. For the polystylen cups, we used the new polystylen cups soaked by deionized water before use. After the glass cups were washed in the hot detergents, they were rinsed by deionized water, and kept in deionized water. These were rinsed two times before filling with analyte. Duplicate analysis were carried out by using the both polystylen cup and glass cup for all samples.

#### c. Calibration

The calibration of all the volumetric flasks used on the cruise were checked before packing.

Calibration of the 6 Eppendorf micropipettes used during the cruise were checked before packing.

#### d. Nutrient standard

We prepared nutrient standards by following "an suggested protocol for continuous flow automated analysis of seawater nutrients" by L. I. Gordon etc. (1992). Nutrient primary standards were prepared from salts dried in oven/microwave oven and cooled over silica gel in a desiccator before weighing. The dry powder for the primary standard was packed in the nitrogen gas atmosphere. The precision of the weighing was ca. 0.1 %. The concentration of A standard are 2500 uM for phosphate, 37500 uM for nitrate and 2000 uM for nitrite, and that of B standard is 3500 uM for silicate.

A uniform set of seven mixed working standards were prepared in LNSW. Concentrations (umol/l) were: nitrate 52.5,45.0,37.5,30.0,15.0,7.5 and 0;

nitrite 1.2,0,0.8,0,0.4,0 and 0; silicate 240,210,175,140,70,35 and 0; phosphate 3.5,3.0,2.5,2.0,1.0,0.5 and 0 thereafter. Since we neglect the highest concentration of working standard in the cruise, the set of six mixed standards were used from the station PR24-3.

e. Duplicate samples and the estimation of the precision of the analysis

There were 43 pairs of duplicate samples drawn. The standard deviation of the differences between duplicate samples (43 pairs) for nitrate, silicate and phosphate is shown in Table 14-1.

Quality control samples at the same depth were also drawn at 7 stations. At each station, samples were drawn from the 4 to 14 of Niskin bottles closed at the same depth and analyzed. The results of the quality control samples are summarized as a range of concentration in Table 14-2.

We also made the 3 to 5 times of repeat analysis of one of the samples at 21 stations. The results of the repeat analysis are summarized as a range of concentration in Table 14-3.

Table 14-1. The standard deviation of the differences between duplicate samples (43 pairs) .

	standard deviation umol/kg	mean concentration umol/kg
Nitrate	0.22	37
Silicate	0.6	142
Phosphate	0.03	2.54

Table 14-2. The results of the quality control samples at the same depth .

Station	n	Nitrate umol/l	Silicate umol/l	Nitrite umol/l	Phosphate umol/l
24-04	6	38.81-39.35	139.7-141.0		2.70-2.76
24-08	6	38.60-39.13	139.8-141.7	0.02-0.05	2.69-2.75
24-09	14	39.14-39.60	131.7-133.4	-0.03-0.00	2.72-2.78
24-16	8	36.93-37.60	142.8-144.2	0.00-0.04	2.55-2.59
24-17	7	36.80-37.12	143.6-144.0	0.02-0.05	2.53-2.57
24-20	4	36.93-37.24	144.7-145.2		2.46-2.56
1S-08	5	37.55-37.76	145.1- 147.7		2.48-2.52

Table 14-3. The results of the repeat analysis as a range of concentration .

Station	n	Nitrate umol/l	Silicate umol/l	Nitrite umol/l	Phosphate umol/l
6N-02	5	39.72-40.35	110.3-110.8	-0.01-0.00	2.71-2.78
6N-06	4	36.60-36.96	143.6-143.8	0.00-0.01	2.49-2.53
6N-10	3	37.03-37.04			2.50-2.53
6N-11	3	36.91-37.15	142.1-143.3		2.51-2.52
6N-13	3		142.8-143.6		2.49-2.54
24-01	3	36.24-36.54			2.47-2.53
24-11	3	36.81-36.93	143.5-143.7	0.00-0.01	2.52-2.53
24-12	4	36.85-37.01	143.7-144.2	0.03-0.04	2.57-2.58
24-14	3	37.00-37.31	144.2-144.4	0.02-0.05	2.37-2.43
24-19	3	36.98-37.10	143.4-144.3		2.44-2.54
1S-01	4	39.28-39.55	113.3-114.4	0.00-0.05	2.78-2.80
1S-04	3	36.82-36.98	143.2-143.8		2.51-2.52
1S-09	3	36.91-36.96	146.2-146.9		2.53-2.55
1S-11	3	36.28-36.66	142.6-143.6		2.50-2.55
1S-13	3	36.58-36.73	140.5-141.0		2.52-2.52
1S-15	3	36.95-37.11	142.4-142.9		2.53-2.56
1S-16	3	36.84-37.26	141.9-142.5		2.53-2.54
1S-17	4	37.49-37.74			2.40-2.53
1S-18	3	10.84-11.29	9.4- 9.5		0.79-0.84
1S-18	3	36.65-37.31	143.0-144.8	0.17-0.17	2.52-2.55
1S-19	3	37.47-37.91	143.7-144.8	-0.02- -0.01	2.54-2.55
1S-21	3	36.84-36.94	141.7-142.2		2.55-2.57

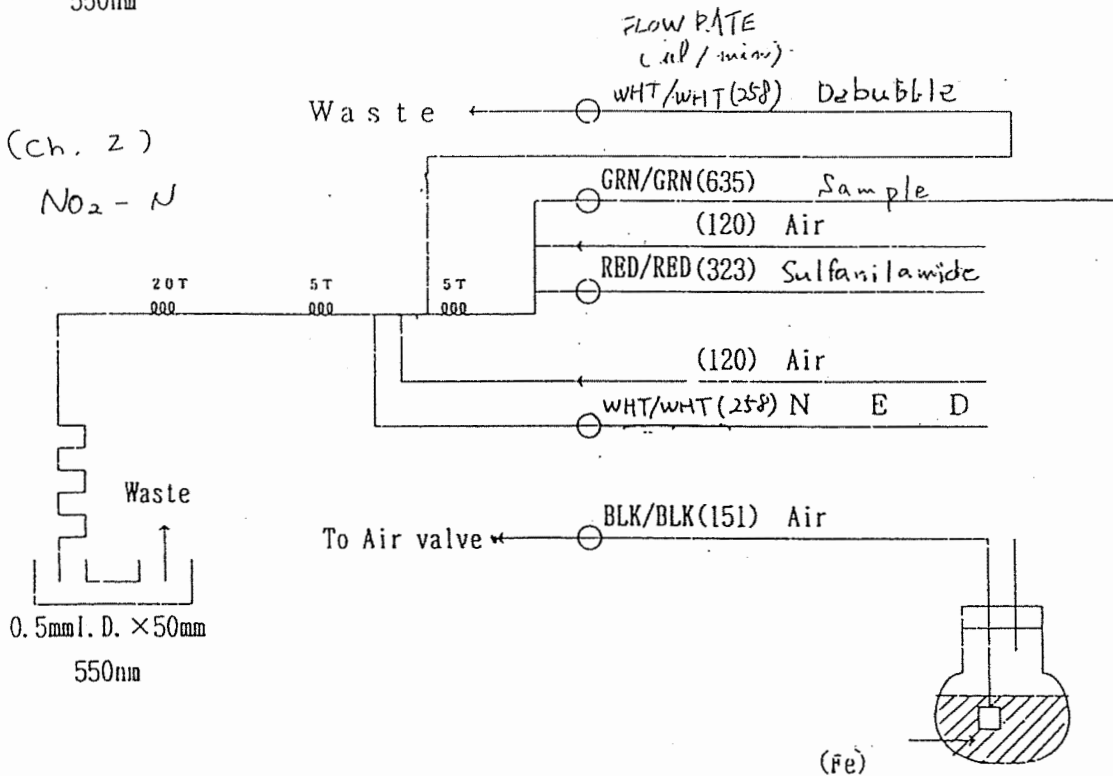
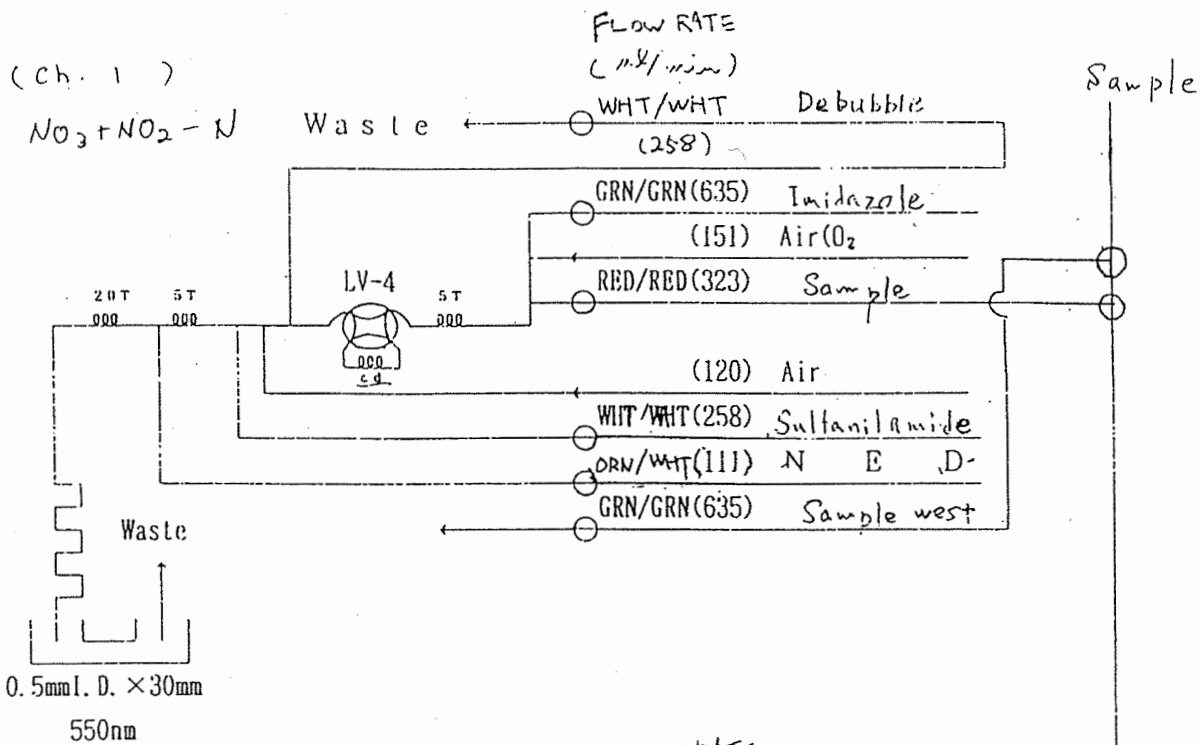

Figure 14-1 (upper) Flow diagram for TRAACS 800 nitrate method

Figure 14-2 (lower) Flow diagram for TRAACS 800 nitrite method

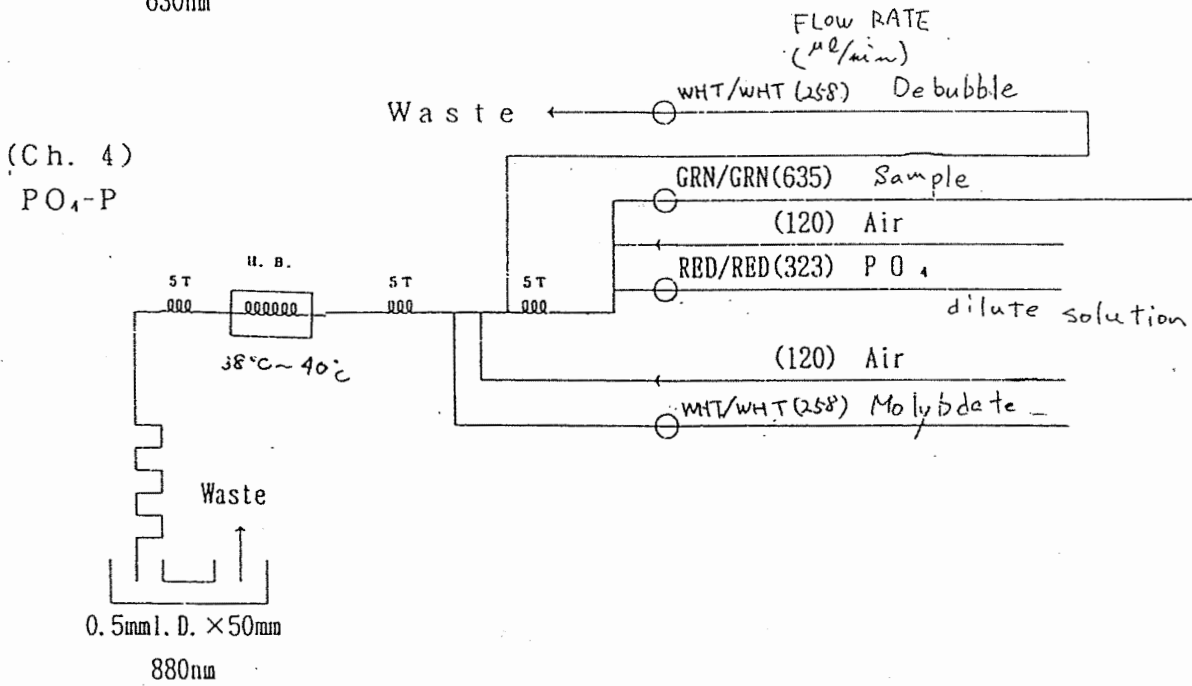
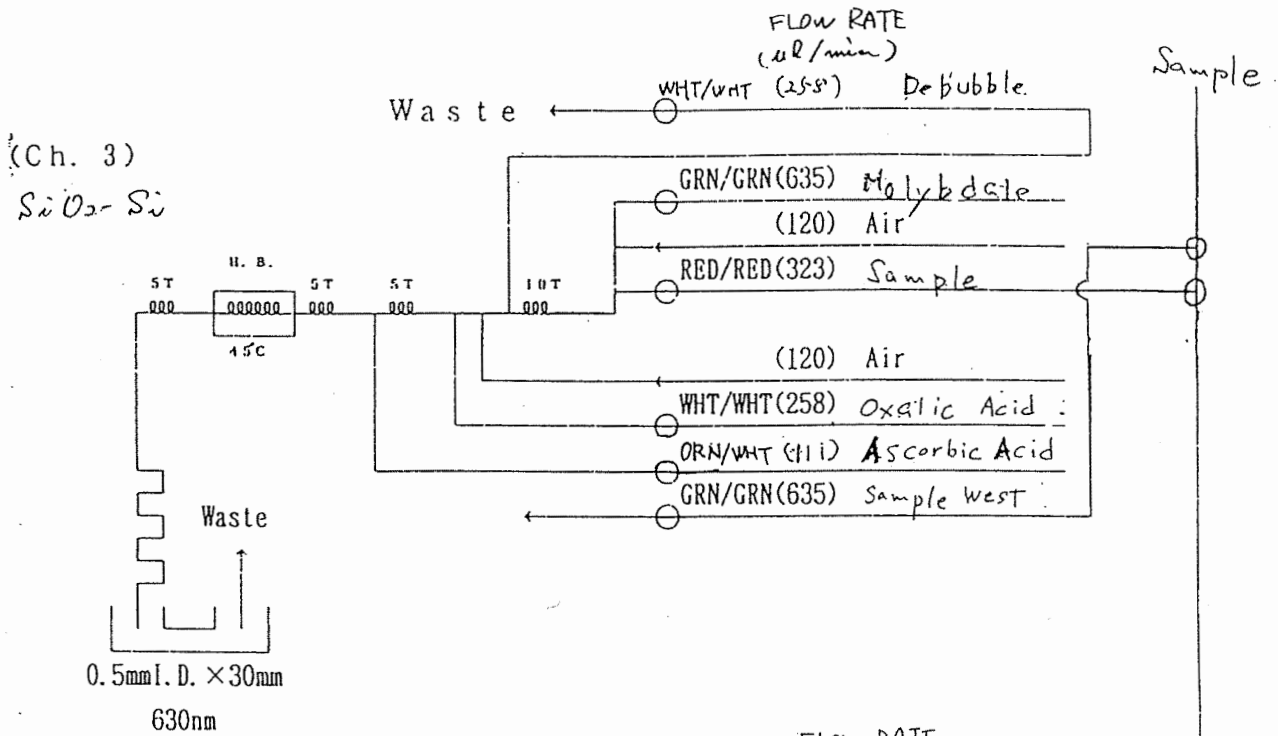

Figure 14-3 (upper) Flow diagram for TRACCS 800 silicate method.

Figure 14-4 (lower) Flow diagram for TRACCS 800 phosphate method.

# 15. Plant Pigments Analysis

by Rusana M. Djalimun (4 March 1994)

## Objectives:

To obtain a pigments data set of the upper layers of the sea by using a spectrophotometric determination method ( - a continuation of LIDAR '94 Cruise/Ocean color data set -).

## Method:

### a. Seawater sampling

Samples were taken in the morning cast of the WOCE '94 cruise sampling stations ( 1 sta./day) from 0 m (surface) , 10 m, 30 m, 50 m, 75 m and 100 m (also 125 m and 150 m at some stations) of depths.

A bucket was used to take the surface seawater samples, and a rosette containing 36 Niskin bottles ( 12 liter volume each) for the other layers.

### b. Filtration and extraction.

About 3 - 10 liters of seawater from each depth was filtered with Nuclepore filter (47mm diameter, 0.4  $\mu$ m pore size from COSTAR Corp., Cambridge, Massachusetts, USA) to trap the phytoplanktons. The filter(s) then soaked in the 6 ml of solvent N,N-dimethylformamide (DMF, from WAKO PURE CHEMICAL INDUSTRIES, Ltd., Japan) solution for 24 hours to extract the pigments.

### c. Absorbance measurement and determination of pigments concentration.

By using a Shimazu UV-2200 spectrophotometer, the absorbance (OD units) of extracted solution of samples were measured at 603 nm, 625 nm, 647 nm, 664 nm, and 703 nm- wavelength. The concentration of pigments ( chlorophyll a and chlorophyll b) were then determined with formulae built by Moran (1981).

## Results and discussion:

The concentration of each sample are shown n Table 15-1.

a. In some stations, where the sea states were heavy, sometimes there was no rosette seawater sampling for upper sea level. In stations of section PR24-2, where a smaller rosette ( 12 Niskin bottles of 5 liter volume) was used, sample was taken only from the surface ( 0 m ) seawater.

b. samples from deeper layers were filtered faster than the upper ones. This must be due to the different concentrations of phytoplanktons at those layers.

c. The concentration of chlorophyll a and chlorophyll b were shown in the table. Chlorophyll a was concentrated mostly at 50 - 100 meters depth, and the concentration became higher around the sea at the triangle formed by stations 6N-9, 6N-15 and PR1S. At most stations, no chlorophyll b was found at 0-30 meters of sea level except for station PR1S-13, and the concentration distribution pattern of chlorophyll b was similar to one of chlorophyll a.

Table 15-1. The Chlorophyll a and chlorophyll b concentration along the section 6N, PR24 and PR1S in 1994 KAIYO WOCE cruise.

Depth meter	Niskin Bottle #	Sample Volume liter	Chl. a mg/m3	Chl. b mg/m3
Station 6N-1				
surface	Bucket	10.0	0.051	-0.004
10	30	9.0	0.043	-0.000
30	28	9.0	0.067	0.001
50	27	9.0	0.132	0.010
100	25	9.0	0.165	0.048
Station 6N-4				
surface	Bucket	10.0	0.065	-0.003
10	36	9.0	0.061	-0.001
30	34	10.0	0.060	0.001
50	33	9.5	0.093	0.005
100	27	10.0	0.213	0.065
Station 6N-8				
surface	Bucket	10.0	0.117	-0.006
30	35	9.5	0.105	-0.001
50	34	10.0	0.096	0.001
100	32	9.5	0.232	0.045
Station 6N-11				
surface	Bucket	10.0	0.059	-0.004
30	35	10.0	0.061	0.004
50	34	9.0	0.183	0.026
75	33	9.0	0.342	0.076
100	32	9.5	0.263	0.058
125	31	10.0	0.169	0.061
150	30	9.0	0.054	0.007
Station 6N-14				

surface	Bucket	10.0	0.051	0.001
100	36	8.5	0.238	0.070

Station PR24-3

surface	Bucket	10.0	0.040	-0.001
30	36	9.0	0.044	0.001
50	35	9.0	0.097	0.029
75	34	9.0	0.215	0.064
100	33	6.5	0.126	0.047

Station PR24-9

surface	Bucket	10.0	0.213	-0.000
10	36	8.0	0.198	0.002
30	34	9.5	0.247	0.002
50	33	9.0	0.299	0.006
75	32	9.0	0.134	0.029
100	31	9.5	0.054	0.007

Station PR24-15

surface	Bucket	10.0	0.171	0.002
10	36	8.0	0.162	0.002
30	34	9.5	0.199	-0.003
50	33	9.0	0.401	0.026
75	31	9.5	0.237	0.088
100	30	9.0	0.107	0.033

Station PR24-2-4

surface	Bucket	10.0	0.172	-0.008
---------	--------	------	-------	--------

Station PR24-16

surface	Bucket	10.0	0.116	-0.001
10	36	7.7	0.125	0.003
30	34	8.3	0.156	0.001
50	33	8.0	0.673	0.117
75	32	8.0	0.242	0.071
100	31	9.0	0.126	0.036

Station PR1S-1

surface	Bucket	10.0	0.144	-0.004
10	36	8.0	0.127	-0.002
30	34	8.0	0.197	0.006
50	33	6.0	0.355	0.042
75	32	9.0	0.271	0.049
100	31	8.0	0.050	0.004

Station PR1S-8

surface	Bucket	10.0	0.126	-0.004
10	36	7.5	0.122	0.003
30	34	5.5	0.345	-0.006
50	33	3.5	0.436	0.059
75	32	7.4	0.262	0.066
100	31	7.5	0.061	0.014

Station PR1S-13

surface	Bucket	10.0	0.243	0.012
10	36	8.5	0.232	0.009
30	34	9.7	0.538	0.147
50	33	7.9	0.254	0.085
75	32	9.5	0.053	0.013
100	31	8.7	0.031	0.007

Station PR1S-18

surface	Bucket	10.0	0.033	-0.001
100	36	10.0	0.230	0.068
125	32	8.0	0.124	0.039
150	31	8.0	0.057	0.011

Station PR1S-20

surface	Bucket	10.0	0.081	-0.009
50	35	9.0	0.290	0.044
100	33	8.0	0.232	0.060

---

## 16. Drifters

by Y. Kashino (9 March 1994)

8 holey sock drifters developed by Scripps Institution of Oceanography were deployed as shown in table 16-1.

Table 16-1. List of drifters deployed on this cruise.

ID	Time of deployment (GMT)	Location	CTD station
20056	25 Feb. 1703	2-00.433N 130-00.058E	PRIS-6
20050	26 Feb. 0455	2-59.935N 129-59.897E	PRIS-9
20052	26 Feb. 1718	4-00.559N 130-00.334E	PRIS-12
20068	27 Feb. 0609	4-59.606N 130-01.085E	PRIS-15
20073	27 Feb. 1940	5-59.657N 129-59.473E	PRIS-17
20046	28 Feb. 0912	7-00.704N 130-01.390E	PRIS-19
20960	1 Mar. 0112	7-30.545N 130-00.000E	PRIS-20
20065	1 Mar. 0805	7-59.592N 130-00.946E	PRIS-21

# 17. Distribution of atmospheric and oceanic CO<sub>2</sub>

by H.Yoshikawa (9 March 1994)

## Objectives

Atmospheric CO<sub>2</sub>, known as a greenhouse gas, has been increasing due to the emission of anthropogenic CO<sub>2</sub>. It has increased approximately 25% in comparison with the pre-industrial era(280ppm). In order to predict the level of atmospheric CO<sub>2</sub> in the future, it is necessary to understand the present inventory among global carbon reservoirs : atmosphere, biosphere and ocean.

CO<sub>2</sub> exchange between the atmosphere and ocean plays an important role in determining the level of atmospheric CO<sub>2</sub>. The difference in partial pressure of CO<sub>2</sub> between the ocean and the atmosphere ( $\Delta p\text{CO}_2$ ) is the driving force for air/sea CO<sub>2</sub> exchange. During the WOCE cruise, measurements of pCO<sub>2</sub> were (will be) made to study the interannual change CO<sub>2</sub> outflux.

## Method

Measurements of the CO<sub>2</sub> concentration in the background air and the air equilibrated with seawater were made using the MRI CO<sub>2</sub> measuring system.

Air sample was taken from the top of the bridge at a flow rate of 15 l/min. Sea water was taken from the bottom of ship continuously, and introduced into the equilibrator.

## Equipment

we use the non-dispersive infrared gas analyzer (BINOS 4, Germany) to determine the CO<sub>2</sub> concentration. CO<sub>2</sub> concentration will be reported based on the WMO X85 mole fraction scale.

## Result

Figure 17-1 is distribution of atmospheric and oceanic CO<sub>2</sub> (preliminary data). The CO<sub>2</sub> trend upward along PR24. This could be caused by the strong upwelling in the eastern equatorial Pacific, and two competitive processes: biological activity and temperature effect.

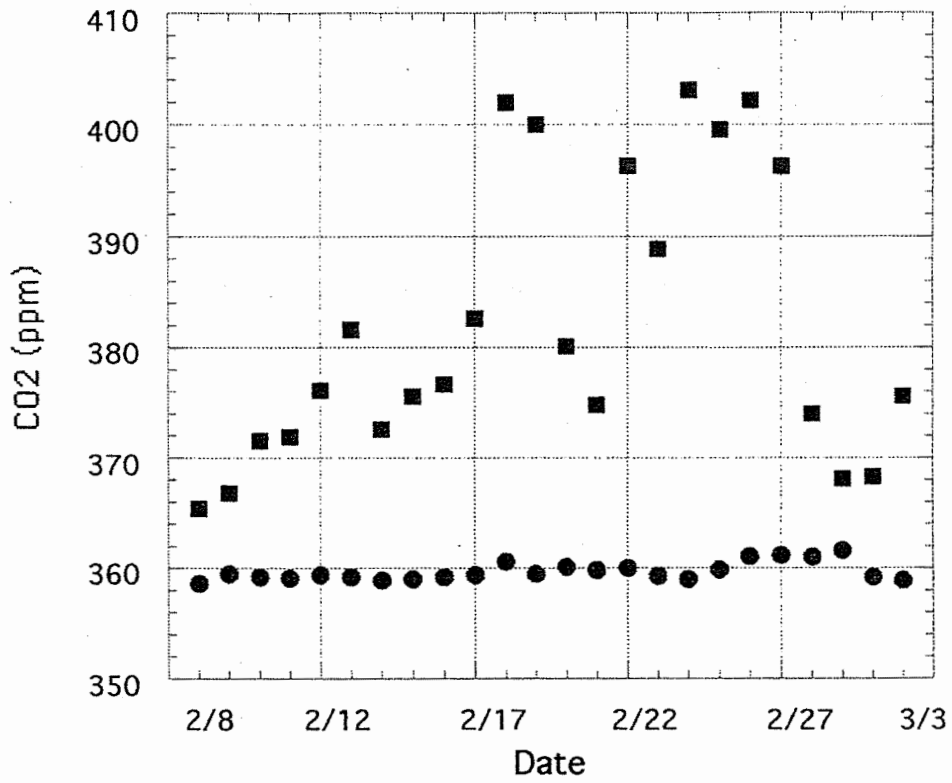

Figure 17-1 Distribution of atmospheric and oceanic CO2 (preliminary data)

- Atmospheric CO2 (ppm)
- Oceanic CO2 (ppm)

## 18. C-14 sample drawing

by M. Aoyama (6 March 1994)

All samples were drawn from 12 liter Niskin bottles followed that for oxygen. Samples were drawn into glass vials of ca. 200 ml. These were rinsed before filling and overflowed by two to three time of the vial volume. Then 0.2 ml of saturated HgCl<sub>2</sub> solution was added and subsequently rubber cap and aluminum cap were clamped to vials.

Replicate samples were drawn from the same rosette bottle at all sampling depths. The sampling depths of radiocarbon samples shallower than 1000 meters were 30, 50, 100, 150, 200, 300, 400, 600, 800, 1000. Below 1000 meters the sampling interval was 500 meters.

## 19. Weather and sea condition

by E. Ukekura ( Chief officer, R/V kaiyo) and M. Aoyama

The 3 hourly weather records are tabulated in Table 19-1.

The Northeasterly trade wind was dominant and the weather was almost fine except sporadic heavy shower in the interested area during the cruise. It was usual weather in the western tropical Pacific and was almost easy.

The air temperature showed the diurnal variation, namely high in afternoon up to 28 to 30 degree Celsius low in evening to morning at 27 to 28 degree Celsius in fine day.

When the heavy shower was observed, the air temperature decreased to 24 to 25 degree Celsius.

The atmospheric pressure showed the semi-diurnal variation. The higher pressure was observed at 0000-0100 UTC and 1300-1500 UTC every day and the lower pressure was observed at 0600-0700 UTC and 1800-2000 UTC every day. The amplitude of the semi-diurnal variation was 2 to 3 hPa.

During the observation along section 6N, the wind speed was around 10 m/s and the wave height was around 2 meters. As the ship heads for south, the wind speed decreased to 5 - 8 m/s, the wind direction become NNE to NNW and the wave height decreased to around 1 meters. The Northeasterly trade wind becomes strong up to 10 to 15 m/s on 28 February and 1 March at the stations from PR1S-17 and PR1S-21, producing the large wave height of 2.5 meters. At the same time, the satellite IR image by GMS Himawari observed the week low moving westerly at 5 degree North, 165 degree East. Since the westerly moving low was predicted to come near our interested area and the sea condition had become hard to operate the CTD/Rosette, R/V Kaiyo headed for Palau Is. in the evening on 1 March.

Table 19-1 Weather observation record WOCE\_meteo

Date/time UTC	Lat. Deg. Min.	Long. Deg. Min.	WD	WS m/s	Temp. Deg. C	Pres. hPa	Ship time
940207/03	07 20 N	134 11 E	NE	6.3	32.0	1007.2	0207/12
940207/06	06 50 N	133 59 E	ESE	10.4	26.2	1007.6	0207/15
940207/09	06 53 N	134 03 E	ESE	8.0	26.5	1009.0	0207/18
940207/12	06 42 N	134 10 E	E	8.5	27.5	1008.9	0207/21
940207/15	06 31 N	134 18 E	ENE	7.5	27.0	1007.4	0208/00
940207/18	06 29 N	134 20 E	ENE	8.0	27.0	1007.1	0208/03
940207/21	06 30 N	134 20 E	ENE	8.0	27.2	1007.6	0208/06
940208/00	06 56 N	134 20 E	NE	8.2	28.2	1009.5	0208/09
940208/03	06 51 N	134 35 E	NE	8.5	28.5	1009.0	0208/12
940208/06	07 11 N	135 00 E	ENE	6.2	26.5	1005.7	0208/15
940208/09	06 48 N	134 39 E	NE	5.4	26.0	1008.1	0208/18
940208/12	06 48 N	134 22 E	NE	6.0	25.8	1009.2	0208/21
940208/15	06 49 N	134 11 E	NE	5.8	26.2	1009.1	0209/00
940208/18	06 48 N	134 02 E	ENE	6.0	26.0	1008.2	0209/03
940208/21	06 51 N	133 59 E	NE	4.0	26.1	1008.6	0209/06
940209/00	07 05 N	133 55 E	ENE	4.7	28.2	1010.6	0209/09
940209/03	06 53 N	133 57 E	NNE	6.4	27.3	1009.6	0209/12
940209/06	06 50 N	133 55 E	ENE	6.5	28.2	1007.4	0209/15
940209/09	06 54 N	133 53 E	ENE	9.7	27.8	1008.1	0209/18
940209/12	06 57 N	133 52 E	ENE	6.0	27.0	1009.1	0209/21
940209/15	06 56 N	133 51 E	ENE	6.5	26.8	1009.5	0210/00
940209/18	06 52 N	133 49 E	ENE	8.0	26.8	1007.9	0210/03
940209/21	06 49 N	133 51 E	ENE	9.4	27.1	1008.5	0210/06
940210/00	06 54 N	133 54 E	ENE	9.5	28.2	1010.0	0210/09
940210/03	06 50 N	133 58 E	ENE	9.6	28.5	1009.2	0210/12
940210/06	06 49 N	133 58 E	ENE	8.0	29.0	1007.3	0210/15
940210/09	06 48 N	134 00 E	NE	11.9	28.0	1007.6	0210/18
940210/12	06 53 N	133 59 E	ENE	12.0	27.0	1009.5	0210/21
940210/15	06 53 N	133 57 E	ENE	10.0	27.0	1009.1	0211/00
940210/18	06 50 N	133 57 E	ENE	12.1	27.0	1007.4	0211/03
940210/21	06 47 N	133 58 E	ENE	12.0	27.1	1007.7	0211/06
940211/00	06 44 N	133 57 E	ENE	11.1	28.5	1009.2	0211/09
940211/03	06 42 N	133 54 E	ENE	7.4	29.5	1008.6	0211/12
940211/06	06 46 N	133 51 E	ENE	11.2	26.5	1007.0	0211/15
940211/09	06 44 N	133 46 E	NE	5.8	26.8	1007.8	0211/18
940211/12	06 50 N	133 49 E	NE	8.5	24.7	1008.6	0211/21
940211/15	06 55 N	133 52 E	ENE	9.0	24.8	1008.5	0212/00
940211/18	06 58 N	133 53 E	E	8.0	27.0	1007.0	0212/03
940211/21	06 57 N	133 53 E	ENE	9.0	27.0	1007.6	0212/06
940212/00	06 58 N	133 53 E	NE	11.0	30.5	1009.2	0212/09
940212/03	06 58 N	133 53 E	ENE	9.0	29.8	1008.9	0212/12
940212/06	06 56 N	133 44 E	ENE	8.0	32.0	1006.8	0212/15
940212/09	06 52 N	133 29 E	ENE	7.0	28.7	1007.0	0212/18
940212/12	06 47 N	133 15 E	ENE	6.9	27.2	1009.8	0212/21
940212/15	06 45 N	133 00 E	ENE	10.0	27.2	1009.5	0213/00
940212/18	06 41 N	132 47 E	NE	10.3	27.0	1008.0	0213/03
940212/21	06 37 N	132 30 E	NE	11.5	27.0	1008.5	0213/06
940213/00	06 35 N	133 21 E	NE	11.5	28.7	1010.4	0213/09

## WOCE\_meteo

940213/03	06	30 N	132	00 E	NE	10.0	30.7	1009.4	0213/12
940213/06	06	28 N	131	55 E	NE	10.0	29.0	1008.2	0213/15
940213/09	06	22 N	131	30 E	NE	10.0	29.2	1008.5	0213/18
940213/12	06	22 N	131	29 E	NE	10.0	27.3	1010.0	0213/21
940213/15	06	15 N	131	03 E	NE	8.5	27.2	1010.1	0214/00
940213/18	06	15 N	131	00 E	ENE	8.0	27.7	1008.6	0214/03
940213/21	06	09 N	130	40 E	ENE	5.7	27.3	1008.4	0214/06
940214/00	06	07 N	130	29 E	E	12.5	25.0	1010.4	0214/09
940214/03	06	05 N	130	22 E	E	11.0	26.2	1010.0	0214/12
940214/06	06	02 N	130	07 E	E	9.9	29.8	1008.1	0214/15
940214/09	06	00 N	130	00 E	ENE	12.0	28.3	1008.4	0214/18
940214/12	06	00 N	129	50 E	E	12.5	27.8	1009.6	0214/21
940214/15	06	00 N	129	30 E	ENE	11.0	27.5	1010.6	0215/00
940214/18	06	00 N	129	30 E	ENE	10.0	27.3	1009.3	0215/03
940214/21	06	00 N	128	59 E	ENE	8.9	27.2	1009.5	0215/06
940215/00	06	00 N	129	00 E	NE	10.0	27.5	1010.3	0215/09
940215/03	06	00 N	128	30 E	NE	9.0	28.8	1010.1	0215/12
940215/06	06	00 N	128	30 E	ENE	6.0	28.8	1008.7	0215/15
940215/09	06	01 N	128	21 E	ENE	7.6	28.5	1009.5	0215/18
940215/12	05	59 N	127	59 E	NE	7.0	27.5	1010.7	0215/21
940215/15	06	00 N	127	58 E	NE	8.0	27.5	1010.4	0216/00
940215/18	06	00 N	127	30 E	NE	7.5	27.0	1010.8	0216/03
940215/21	05	58 N	127	28 E	NE	6.5	26.6	1010.4	0216/06
940216/00	05	58 N	127	29 E	NNE	7.5	27.5	1011.7	0216/09
940216/03	06	00 N	127	07 E	NNE	5.8	28.2	1011.2	0216/12
940216/06	06	00 N	127	00 E	NNE	8.0	28.5	1009.2	0216/15
940216/09	05	43 N	127	10 E	NNE	10.5	28.5	1009.0	0216/18
940216/12	05	44 N	127	09 E	NNE	11.0	28.0	1010.6	0216/21
940216/15	05	27 N	127	20 E	NNE	9.5	27.0	1010.5	0217/00
940216/18	05	25 N	127	18 E	NNE	4.0	25.0	1009.6	0217/03
940216/21	05	17 N	127	24 E	NE	6.8	26.2	1009.5	0217/06
940217/00	05	10 N	127	28 E	NE	9.0	27.8	1011.0	0217/09
940217/03	05	02 N	127	32 E	NE	8.5	29.0	1010.7	0217/12
940217/06	04	53 N	127	40 E	NE	5.0	28.2	1008.7	0217/15
940217/09	04	54 N	127	40 E	NNE	6.0	29.5	1009.0	0217/18
940217/12	04	36 N	127	51 E	NE	6.0	27.1	1010.0	0217/21
940217/15	04	25 N	127	56 E	NNE	6.8	27.0	1010.5	0218/00
940217/18	04	17 N	128	03 E	NNE	6.0	26.7	1009.3	0218/03
940217/21	04	03 N	128	10 E	NNW	3.3	26.5	1010.0	0218/06
940218/00	03	49 N	128	20 E	NNE	2.4	27.9	1011.7	0218/09
940218/03	03	44 N	128	22 E	N	3.0	29.0	1010.8	0218/12
940218/06	03	30 N	128	29 E	NW	4.0	29.0	1009.0	0218/15
940218/09	03	30 N	128	30 E	NW	5.0	28.6	1009.5	0218/18
940218/12	03	22 N	128	34 E	NW	3.0	26.3	1010.5	0218/21
940218/15	03	16 N	128	38 E	NNW	2.1	26.8	1010.5	0219/00
940218/18	03	08 N	128	43 E	WNW	5.0	26.5	1009.0	0219/03
940218/21	02	57 N	128	49 E	NW	5.0	27.3	1009.5	0219/06
940219/00	02	41 N	128	58 E	W	4.9	27.3	1010.7	0219/09
940219/03	02	40 N	129	00 E	NW	6.0	28.3	1010.0	0219/12
940219/06	02	51 N	128	42 E	NNW	3.5	28.2	1008.7	0219/15

WOCE\_meteo

940219/09	02	51 N	128	41 E	NNW	6.8	29.8	1008.5	0219/18
940219/12	03	00 N	128	24 E	NNW	5.0	26.8	1009.9	0219/21
940219/15	03	10 N	128	20 E	NNE	6.4	27.0	1010.6	0220/00
940219/18	03	16 N	128	18 E	N	5.0	26.5	1009.1	0220/03
940219/21	03	29 N	128	11 E	N	5.2	27.2	1010.0	0220/06
940220/00	03	41 N	128	02 E	NNW	5.8	28.4	1011.2	0220/09
940220/03	03	49 N	127	53 E	NNW	6.2	28.5	1010.5	0220/12
940220/06	03	57 N	127	39 E	NNW	6.0	30.2	1009.6	0220/15
940220/09	04	03 N	127	25 E	NNE	6.0	30.1	1009.2	0220/18
940220/12	04	10 N	127	15 E	N	5.9	26.9	1010.4	0220/21
940220/15	04	03 N	127	27 E	NNE	6.9	26.8	1010.7	0221/00
940220/18	04	00 N	127	31 E	N	7.0	26.2	1008.8	0221/03
940220/21	03	59 N	127	32 E	NNE	5.0	26.2	1008.9	0221/06
940221/00	04	00 N	127	32 E	N	5.0	29.0	1010.6	0221/09
940221/03	03	54 N	127	35 E	NNE	5.5	28.8	1009.5	0221/12
940221/06	03	27 N	127	53 E	NNE	5.0	29.0	1007.8	0221/15
940221/09	03	27 N	127	54 E	N	5.0	29.0	1008.1	0221/18
940221/12	03	25 N	128	03 E	N	5.0	28.0	1010.0	0221/21
940221/15	03	20 N	128	13 E	NNW	5.0	27.2	1010.6	0222/00
940221/18	03	15 N	128	22 E	NNW	4.5	27.0	1009.3	0222/03
940221/21	03	12 N	128	26 E	NW	6.0	26.8	1009.6	0222/06
940222/00	03	11 N	128	29 E	NNW	5.5	28.5	1011.2	0222/09
940222/03	03	11 N	128	29 E	NNE	6.0	28.0	1011.2	0222/12
940222/06	03	11 N	128	27 E	NNW	8.0	29.0	1008.6	0222/15
940222/09	03	12 N	128	26 E	N	6.6	28.2	1008.7	0222/18
940222/12	03	16 N	128	21 E	N	7.0	27.0	1010.2	0222/21
940222/15	03	20 N	128	10 E	NNE	6.5	26.8	1010.2	0223/00
940222/18	03	24 N	128	00 E	NNE	7.2	27.0	1008.8	0223/03
940222/21	03	27 N	127	53 E	NNE	6.7	27.3	1009.3	0223/06
940223/00	03	27 N	127	53 E	N	5.0	28.5	1011.0	0223/09
940223/03	03	21 N	128	01 E	NNE	6.0	28.5	1010.9	0223/12
940223/06	03	10 N	128	14 E	N	4.0	28.0	1008.5	0223/15
940223/09	03	01 N	128	25 E	NNE	3.8	30.5	1008.6	0223/18
940223/12	02	51 N	128	38 E	N	4.3	27.5	1010.3	0223/21
940223/15	02	43 N	128	51 E	NNW	4.5	27.5	1011.2	0224/00
940223/18	02	33 N	129	02 E	NNW	4.5	26.5	1009.2	0224/03
940223/21	02	26 N	129	08 E	NNW	4.2	27.2	1009.5	0224/06
940224/00	02	23 N	129	10 E	NW	4.5	28.2	1009.5	0224/09
940224/03	02	18 N	129	13 E	NW	5.0	29.5	1011.2	0224/12
940224/06	02	06 N	129	19 E	N	8.5	30.5	1008.8	0224/15
940224/09	01	51 N	129	29 E	NNE	8.9	28.1	1009.1	0224/18
940224/12	01	51 N	129	29 E	NNE	10.5	27.0	1010.4	0224/21
940224/15	01	30 N	129	41 E	N	4.0	27.2	1011.8	0225/00
940224/18	01	30 N	129	41 E	N	4.5	26.5	1009.2	0225/03
940224/21	01	02 N	129	53 E	NNW	5.7	26.8	1009.2	0225/06
940225/00	00	45 N	130	00 E	N	6.5	28.5	1010.5	0225/09
940225/03	01	00 N	130	00 E	N	6.5	30.5	1009.6	0225/12
940225/06	01	14 N	130	00 E	N	10.0	30.0	1007.3	0225/15
940225/09	01	30 N	129	59 E	NNE	6.0	27.0	1008.1	0225/18
940225/12	01	41 N	130	00 E	NNE	9.0	26.5	1009.6	0225/21

WOCE\_meteo

940225/15	02	00 N	130	00 E	NNE	9.0	27.3	1010.2	0226/00
940225/18	02	09 N	130	00 E	NNE	7.5	26.0	1008.3	0226/03
940225/21	02	30 N	130	00 E	NNE	10.0	27.0	1008.1	0226/06
940226/00	02	40 N	130	00 E	N	9.2	27.7	1009.6	0226/09
940226/03	03	00 N	130	00 E	N	10.0	30.2	1009.7	0226/12
940226/06	03	10 N	130	00 E	N	10.0	29.0	1007.0	0226/15
940226/09	03	30 N	130	00 E	N	9.0	29.0	1008.1	0226/18
940226/12	03	39 N	130	00 E	N	9.5	27.2	1009.6	0226/21
940226/15	04	00 N	130	00 E	N	10.0	26.8	1010.4	0227/00
940226/18	04	07 N	130	00 E	N	9.0	26.3	1009.4	0227/03
940226/21	04	30 N	130	00 E	NNE	9.0	26.6	1009.6	0227/06
940227/00	04	36 N	130	00 E	NNE	10.5	28.2	1010.6	0227/09
940227/03	05	00 N	130	00 E	NNE	9.5	28.8	1010.7	0227/12
940227/06	05	00 N	130	00 E	NNE	7.0	29.0	1007.9	0227/15
940227/09	05	28 N	130	00 E	NNE	9.0	27.0	1008.6	0227/18
940227/12	05	30 N	130	01 E	NE	8.5	26.8	1010.0	0227/21
940227/15	05	48 N	130	00 E	NE	9.0	26.5	1010.5	0228/00
940227/18	06	00 N	130	00 E	ENE	8.5	26.2	1009.3	0228/03
940227/21	06	11 N	130	00 E	ENE	9.1	27.0	1009.1	0228/06
940228/00	06	30 N	130	00 E	E	11.0	28.0	1010.9	0228/09
940228/03	06	38 N	130	00 E	ENE	12.0	28.5	1010.3	0228/12
940228/06	07	00 N	130	00 E	NE	12.5	29.0	1009.3	0228/15
940228/09	07	00 N	130	00 E	NE	13.5	27.0	1009.1	0228/18
940228/12	07	09 N	130	00 E	NE	14.0	27.0	1010.5	0228/21
940228/15	07	16 N	130	00 E	NE	12.0	26.7	1011.0	0301/00
940228/18	07	22 N	130	00 E	ENE	12.0	25.5	1009.6	0301/03
940228/21	07	28 N	130	00 E	NNE	10.0	26.2	1009.6	0301/06
940301/00	07	30 N	130	00 E	NE	7.5	27.0	1011.7	0301/09
940301/03	07	46 N	130	00 E	NE	8.5	27.2	1011.2	0301/12
940301/06	08	00 N	130	00 E	NE	12.0	27.0	1010.0	0301/15
940301/09	07	52 N	130	00 E	NNE	8.8	27.5	1010.0	0301/18
940301/12	07	31 N	130	06 E	NE	10.0	26.5	1010.7	0301/21
940301/15	07	30 N	130	29 E	NE	12.0	26.8	1010.7	0302/00
940301/18	07	30 N	130	49 E	NE	9.5	26.5	1008.8	0302/03
940301/21	07	30 N	130	11 E	NNE	11.8	26.8	1008.7	0302/06
940302/00	07	30 N	131	35 E	NNE	10.5	26.5	1010.0	0302/09
940302/03	07	30 N	132	01 E	NNE	12.5	27.2	1009.7	0302/12
940302/06	07	30 N	132	26 E	NE	3.0	28.5	1008.2	0302/15
940302/09	07	31 N	133	04 E	NNE	3.1	27.0	1009.4	0302/18
940302/12	07	32 N	133	16 E	NNE	4.5	26.7	1010.2	0302/21
940302/15	07	33 N	133	40 E	NNE	2.0	26.3	1010.6	0303/00
940302/18	07	35 N	133	54 E	ESE	3.0	26.0	1009.1	0303/03
940302/21	07	35 N	134	07 E	ESE	5.4	26.8	1009.0	0303/06
940303/00	07	35 N	134	07 E	SE	5.0	28.5	1011.2	0303/09

Palau arrival

## 20. Problems

by K Muneyama and M. Aoyama

We had 4 times of a disconnection of seacable. We spent 2 to 3 hours for fixing the disconnections. The most serious problem we encountered in this cruise was a total loss of a cast data at one occasion. We monitored the profiles of temperature, salinity and dissolved oxygen, and also watched reading of CTD pressure. After CTD/rosette was retrieved on the deck, an operator has intended to copy the file. Then he noticed that a size of datafile was zero byte, however the header file had been stored. The cause of this accident might be a computer virus, or a software bug, or an accidental mechanical failure. But we still could not elucidate the cause.

We could not retrieve the 2 Aanderaa currentmetre moorings deployed in October 1992 placed between Talaud and Morotai islands, even though each acoustic releaser had worked normally.

This R/V Kaiyo is designed to have a wide open deck for setting up many ship boarding containers, and consequently rather small fixed laboratory space. We provided a ship boarding container for a water sampling room with two air conditioners. The CTD/rosette water sampler itself is narrowly kept in the space, however operations for water sampling might be affected to be less convenient and less efficient.

Dissolve Oxygen measurement of bottle samples has required us the precisely controlled room temperature, however, the room temperature of the laboratory varied at 18 to 21 degC in this occasion. We need to have a better control of the room temperature for more difficult analysis.

We have detected "the shed wake". This error could not be corrected.

## 21. REPORT ON CTD SYSTEM PERFORMANCE

RV KAIYO, WOCE 94 CRUISE, SBE 911plus Serial Number 09P8010-0319

By Richard Baumann, Technical Operations Manager, SEA-BIRD Electronics, Inc. ,  
Bellevue, WA USA ( 3 March 1994)

This report is a analysis of the performance of a SBE 911plus CTD system during a WOCE hydrography cruise on the Research Vessel KAIYO. The CTD system and vessel belong to the Japan Marine Science and Engineering Center (JAMSTEC). At their request, Mr. R. Baumann from Sea-Bird Electronics, Inc. (SBE) participated in the cruise to help with any problems that occurred with the CTD and to give his observations on the operation and performance of the CTD system.

This report was written during the cruise and is divided into four parts. The first part is a brief description of the CTD system followed by a discussion of the steps that SBE recommends be followed in the operation of the CTD and the subsequent analysis and calibration of the CTD data to achieve WOCE accuracy specifications. The second part of the report is an analysis of the accuracy of the data obtained during the cruise. The third section is a discussion of the general operation of the CTD during the cruise with some examples of the data taken. The fourth part is a brief conclusion.

### PART I THE SBE 9plus CTD

The primary CTD underwater unit used for this cruise was a SBE 9plus, S/N 09P8010-0319. This CTD has dual temperature and conductivity sensors and a 15,000 psia Digiquartz pressure sensor. The main CTD and sensor housings are titanium giving the CTD system a depth capability of 10,500 meters. The CTD was delivered to JAMSTEC in October of 1993. The serial numbers and the factory calibration dates for the sensors mounted on this CTD as used on the cruise are:

Primary temperature sensor S/N 1462 calibrated 28 September 1993

Primary conductivity sensor S/N 1045 calibrated 09 September 1993

Secondary temperature sensor S/N 1465 calibrated 28 September 1993

Secondary conductivity sensor S/N 1174 calibrated 22 September 1993

Paroscientific Inc. 15,000 psia pressure sensor calibration dated 24 September 1993

Experience has shown that the calibration of the pressure sensor will change as a slow drift of offset with time (approximately 1 to 2 dbar per year). Before a cast the pressure reading on deck should be observed and this value used as an offset to zero the pressure reading in air.

The temperature sensors will tend to drift via a slowly increasing offset with time. This offset (which will be nominally the same at all temperatures) may be of either sign and will tend to be at a constant rate (from 0 to  $\pm 0.010$  deg C per year) over periods of years. The temperature sensors on this CTD were calibrated monthly for a period of 9 months before they were supplied with the CTD system. This is sufficient time to determine their initial drift histories and allows their drift to be predicted with reasonable accuracy for periods of months before they need to be calibrated to verify the actual drift since their last calibration. The drift histories of the temperature sensors on this CTD are included as Figures 21-1 and -2 in this report. Based on an examination of these histories it is felt that as of 15 February 1994 both of these sensors will be reading 0.0028 deg C low (as referenced to the 28 September 1993 calibration coefficients used at sea) and that an offset correction of +0.0028 deg C should be added to the factory calibrations for each of these sensors. This prediction of temperature sensor drift is supported by an analysis in part two of this report where it is shown that the two temperature sensors agree with each other to within about 0.0006 deg C throughout the cruise.

Conductivity sensors tend to drift with use in two ways. One is a small background drift that can be considered uniform with time. This is thought to be a measure of the gradual fouling and aging of the platinum electrodes. Superimposed on this may be larger fouling events that are related to contact with biological material in the water as it passes through the cell. This type of fouling is seen as a larger shift in the conductivity measurement (towards lower conductivity) on top of the slower background drift. Rinsing the conductivity cell with a 2 to 5% solution of Triton detergent after each cast will help minimize the drift experienced during use. The error in the conductivity sensor is a function of the conductivity value and the correction is a slope adjustment to conductivity. After corrections have been made for the temperature and pressure sensors the calculation of the error in the conductivity measurement can be determined in two ways. One is based upon an analysis of the independent measurement of salinity from insitu water samples collected during the cruise. The other method is to have the conductivity sensor calibrated after the cruise and to base a correction on the observed drift. The first method has the advantage that it will tend to catch the aperiodic fouling events where the

second method will average them over the duration of the cruise. An analysis of the CTD and Autosal salinity data from this cruise is given in the second part of this report.

To insure that the WOCE accuracy specifications are met it is necessary to regularly calibrate the temperature and conductivity sensors on the SBE 9plus CTD. SBE would recommend that this be at least once a year and for the highest accuracy, calibrations before and after each cruise would be appropriate. Regular calibrations will also establish histories of the performance of the temperature and conductivity sensors. These histories allow the drift of the temperature sensor to be predicted and verify the operational characteristics of the conductivity sensor.

The discussion above on calibrations is concerned with the static accuracy of the CTD system. This is the accuracy that the CTD and its sensors can obtain in a uniform, homogenous environment such as a calibration bath. The ocean, however, is not a uniform environment and the dynamic accuracy (the ability of the CTD to measure a parameter as it changes) of the CTD system must be considered. A full discussion of this subject is beyond the scope of this report but it is important to recognize that during data processing the appropriate corrections should be made for those errors that can be corrected (cell thermal mass, misalignment of temperature and conductivity data) and that the data containing errors that can not be corrected (shed wakes) be eliminated from further data processing. In part two of this report the analysis of data will be done in deeper water where gradients (and the resulting dynamic errors) are small.

The SBE 9plus as used in the cruise was removed from its factory supplied cage and mounted vertically in the middle of a General Oceanics Model 1016 36 position, 12 liter, rosette water sampler. As mounted the CTD sensors had a good view of unobstructed water during down cast operation. SBE recommends that the CTD be lowered at a drop speed of between 1.0 and 1.5 meter per second. The CTD was deployed from an A-frame at the stern of the KAIYO and because of operational constraints was lowered at a descent rate of 0.5 meter per second (m/s) until a depth of 200 meters at which time the rate was increased to 1.5 m/s until within 200 meters of the bottom when the rate was slowed to 0.5 m/s. During CTD operations the bow of the ship is normally turned into the wind to help maintain a stationary position during the cast. In this orientation the predominant ship motion is pitch which modulates the descent rate when the CTD is deployed over the stern. The coupling of the pitch of the ship with the descent rate can cause the CTD to slow down, stop or even reverse directions and move up towards the surface. When this happens the water that has been entrained by the rosette will

continue to move at the original descent rate and will cause a mixing of the water being measured by the CTD sensors. This will contaminate the data to an extent where this data must be removed from future analysis. This problem is most severe in the upper ocean where vertical gradients are the largest but can also affect data in the deep ocean. Examples of this type of data are given in part three of this report.

## PART II ACCURACY ANALYSIS OF THE SBE 9plus CTD

The CTD used for this cruise was equipped with dual temperature and conductivity sensors. This feature allows for the comparison of data from each sensor pair as a check of data quality. This check is best performed below the thermocline where errors associated with the strong gradients of temperature and salinity are at a minimum.

### COMPARISON OF TEMPERATURE SENSORS.

Table 21-1. contains a comparison of the temperatures reported by the primary (T0) and secondary (T1) sensors at two depths for selected casts throughout the cruise. These data points represent 10 second averages obtained when the CTD was stopped to collect insitu water samples. The temperatures in this table are as calculated using the 28 September 1993 calibration coefficients. The data show that the primary sensor is reading approximately 0.0006 deg C higher than the secondary sensor. This agreement supports the idea that both sensors have continued to drift at the rates predicted in the first part of this report. A post calibration of the sensors would determine the actual adjustments needed to bring these measured temperatures to the true temperature. The data at 2000 dbar show a higher variance then the data at 3000 dbar; which can be related to the steeper temperature gradient at that depth and the subsequent mixing of the water as the CTD/water sampler is stopped to collect a water sample (where the motion is that imparted to the instrument package by ship motion). With the good agreement shown between sensors either sensor could be used for subsequent data analysis.

### COMPARISON OF SALINITY CALCULATED WITH PRIMARY AND SECONDARY SENSOR PAIRS.

Table 21-2. contains a comparison of the salinity calculated using the primary (S0) and secondary (S1) sensor pairs at two depths for selected casts throughout the cruise. These data points represent 10 second averages obtained when the CTD was stopped to collect insitu water samples. Salinity was calculated using the data as recorded by the SEASAVE program; no further data processing was performed and no corrections have been made to the calibration coefficients. The data show good agreement with the primary sensor pair giving a salinity which is slightly larger ( $<0.001$ ) than the secondary salinity during the first part of the cruise but which varies as the cruise progresses. Unlike temperature whose calibration should not significantly change during a 1 month cruise, conductivity sensor calibrations will change as the cell is used. A more complete description of drift of a conductivity sensor is contained in the first part of this report. With the agreement between salinity either pair could be used for subsequent data analysis.

#### COMPARISON OF THE DEEP SALINITY DATA BETWEEN CASTS

In the deep water (4000 dbar and below) of the area of the Pacific Ocean where this survey is located it is not expected that the salinity will vary significantly either with location or depth. If this assumption is true than the salinity values observed at these depths can be used to monitor the calibration drift of the conductivity sensors. Table 21-3 is a compilation of 10 second average CTD (primary sensor pair) salinity values for all water sample locations between 4000 and 5000 dbars. The salinity values in this table have been adjusted by  $-0.0029$  psu from the values obtained with the factory calibration coefficients to reflected the predicted drift correction of  $+0.0028$  deg C applied to the temperature sensor. The table shows agreement to within  $0.0005$  psu for depths between 4250 and 5000 for casts K6N021 through K6N121. After this cast there appears to be a trend towards lower salinity values with casts K6N131 being somewhat between and casts K6N141 thru K1S122 being about  $0.001$  PSU lower than the initial values. This is followed by casts K1S132 thru K1S182 being about  $0.0015$  lower than the initial values. The behavior is consistent with a conductivity cell which is gradually shifting calibration as it is used. Stations K6N091 and K1S172 were at the same location and the approximate  $0.0015$  difference in salinity between the two stations supports the analysis given here. At the time of this report was written the Autosal salinity values were only available through station K24202. When this information and the post calibrations are available there should be sufficient information to determine the actual calibration of the conductivity sensor at the various stations.

Table 21- 3. clearly illustrates the ability of the SBE 911plus CTD system to resolve salinity to better than 0.0003 psu in the deep water where gradients (and the resulting dynamic errors) are low. Figure 21- 3. (which is discussed below) graphically presents this level of CTD precision for data points at or below 4000 dbar for stations up to K24031. Figure 21- 4 in the third section of this report shows the noise level of the unaveraged 24 hz salinity data in deep water to be about 0.001 psu.

#### COMPARISON OF CTD SALINITY WITH AUTOSAL SALINITY

Table 21- 4 lists the difference between CTD salinity (S0) and salinity calculated from insitu water samples between 4000 and 5000 meters for those casts for which Autosal salinity was available when this report was written. Figure 21- 3 shows this data along with the data from Table 21- 3 in a graphical format. It is easily seen that the variance of the averaged CTD salinity is much less than the salinity measured from the insitu water samples. Where Table 21- 3 suggests a slow change in the calibration of the conductivity sensor this trend is not obvious in the water bottle data available at the time this report was written.

#### PART III GENERAL PERFORMANCE AND EXAMPLES OF SBE 9plus CTD DATA

In part two of this report data were presented that represented 10 second averages obtained when the CTD was held at a depth to obtain a insitu water sample. Figure 21- 4 is a sample of the full rate 24 hz data from which these averages were calculated. This data is as recorded by the SEASAVE program without subsequent post processing. The noise level for temperature is less than 0.001 deg C and for salinity is approximately 0.001 psu respectively. This data also shows the 0.1 dbar jitter in the pressure measurement which is removed by lowpass filtering pressure with a 0.15 second time constant. The increased variance of the signal during periods of low or negative descent rate is caused by mixing induced by the CTD/water sampler along the small local temperature gradient. The secondary sensor pair gives comparable data.

Figure 21- 5 is an example of shed wakes in the data that occur when the motion of the CTD/water sampler through the water column slows and allows the entrained water to overtake the sensor package and be measured as if it were new, undisturbed water. The data during these periods can not be easily corrected and should be removed from subsequent data analysis.

#### PART IV CONCLUSIONS

Based on the evidence presented here this it appears that after the zero offset of the pressure sensor is adjusted for and a offset correction is added for the predicted drift of the temperature sensors, the CTD initially was giving a salinity which was about 0.002 psu low of the average insitu samples. As the cruise progressed this difference increased to about 0.0035 psu.

In summary, the SBE 911plus CTD system used on this cruise showed the same high quality data which are typical of results obtained elsewhere. Temperature, salinity, and pressure that are within the WOCE requirements can be obtained from this data set when careful attention is paid to the calibration of the sensors. It is highly recommended that the temperature and conductivity sensors used be calibrated after the cruise to confirm the corrections made at sea.

Table 21-1 Comparison Between Primary and Secondary Temperature Sensors

T0 is primary temperature, T1 is secondary temperature. Diff = T0 - T1

Cast#	2000 dbar			3000 dbar		
	T0	T1	Diff	T0	T1	Diff
K6N011	2.2144	2.2137	+0.0007	1.5681	1.5676	+0.0005
K6N021	2.1756	2.1750	+0.0006	1.5951	1.5945	+0.0006
K6N031	2.1642	2.1635	+0.0007	1.6224	1.6219	+0.0005
K6N041	2.1262	2.1247	+0.0015	1.5865	1.5858	+0.0007
K6N051	2.2463	2.2468	-0.0005	1.5919	1.5908	+0.0011
K6N061	2.2440	2.2437	+0.0003	1.6178	1.6173	+0.0005
K6N071	2.3083	2.3072	+0.0011	1.6131	1.6125	+0.0006
K6N081	2.2619	2.2602	+0.0017	1.6153	1.6148	+0.0005
K6N091	2.2408	2.2404	+0.0004	1.6033	1.6028	+0.0005
K6N101	2.3044	2.3039	+0.0005	1.6051	1.6044	+0.0007
K6N111	2.2248	2.2243	+0.0005	1.6161	1.6156	+0.0005
K6N121	2.0897	2.0889	+0.0008	1.6028	1.6021	+0.0007
K6N131	2.0553	2.0545	+0.0008	1.6217	1.6211	+0.0006
K6N141	2.1019	2.1018	+0.0001	1.5876	1.5868	+0.0008
K6N151	2.2766	2.2749	+0.0017	1.5855	1.5850	+0.0005
K24011	2.1761	2.1768	-0.0007	1.5807	1.5799	+0.0008
K24021	2.2166	2.2158	+0.0008	1.5730	1.5724	+0.0006
K24031	2.1578	2.1600	-0.0022	1.5832	1.5825	+0.0007
K24061	2.0914	2.0915	-0.0001	1.5934	1.5933	+0.0001
K24071	2.2125	2.2121	+0.0004	---	---	---
K24081	2.1029	2.1022	+0.0007	---	---	---
K24112	2.2163	2.2152	+0.0011	1.5704	1.5699	+0.0005
K24122	2.3027	2.3025	+0.0002	1.6034	1.6032	+0.0002
K24162	2.2728	2.2738	-0.0010	1.5795	1.5790	+0.0005
K24172	2.3377	2.3374	+0.0003	1.5971	1.5964	+0.0007
K24192	2.1735	2.1729	+0.0006	1.5753	1.5747	+0.0006
K24202	2.2070	2.2055	+0.0015	1.5585	1.5581	+0.0004
K1S022	2.2499	2.2495	+0.0004	1.5457	1.5453	+0.0004
K1S042	2.2585	2.2589	-0.0004	1.5829	1.5823	+0.0006
K1S062	2.2892	2.2884	+0.0008	1.5608	1.5601	+0.0007
K1S082	2.2188	2.2178	+0.0010	1.5923	1.5919	+0.0004
K1S092	2.3048	2.3041	+0.0007	1.5875	1.5872	+0.0003
K1S112	2.3373	2.3382	-0.0009	1.5751	1.5747	+0.0004
K1S122	2.2709	2.2702	+0.0007	1.5737	1.5736	+0.0001
K1S132	2.2230	2.2222	+0.0008	1.6087	1.6081	+0.0006
K1S152	2.1668	2.1663	+0.0005	1.5827	1.5823	+0.0004
K1S172	2.2860	2.2858	+0.0002	1.6179	1.6172	+0.0007
K1S182	2.3836	2.3844	-0.0008	1.6201	1.6193	+0.0008

Table 21-2 Salinity Comparison Between Primary and Secondary Sensors

Salinity has been calculated with factory coefficients only. No corrections have been applied.  
 S0 is salinity calculated using primary temperature and primary conductivity.  
 S1 is salinity calculated using secondary temperature and secondary conductivity.  
 Diff = S0 - S1

Cast#	2000 dbar			3000 dbar		
	S0	S1	Diff	S0	S1	Diff
K6N011	34.6334	34.6339	-0.0005	34.6729	34.6734	-0.0005
K6N021	34.6358	34.6360	-0.0002	34.6712	34.6714	-0.0002
K6N031	34.6358	34.6358	+0.0000	34.6696	34.6694	+0.0002
K6N041	34.6371	34.6369	-0.0002	34.6720	34.6717	+0.0003
K6N051	34.6315	34.6312	+0.0003	34.6709	34.6708	+0.0001
K6N061	34.6328	34.6325	+0.0003	34.6688	34.6685	+0.0003
K6N071	34.6302	34.6300	+0.0002	34.6688	34.6685	+0.0003
K6N081	34.6318	34.6315	+0.0003	34.6691	34.6688	+0.0003
K6N091	34.6329	34.6326	+0.0003	34.6700	34.6696	+0.0004
K6N101	34.6303	34.6294	+0.0009	34.6697	34.6690	+0.0007
K6N111	34.6338	34.6330	+0.0008	34.6685	34.6677	+0.0008
K6N121	34.6398	34.6390	+0.0008	34.6690	34.6684	+0.0006
K6N131	34.6411	34.6404	+0.0007	34.6679	34.6672	+0.0007
K6N141	34.6379	34.6373	+0.0006	34.6699	34.6694	+0.0005
K6N151	34.6289	34.6278	+0.0011	34.6700	34.6689	+0.0011
K24011	34.6327	34.6320	+0.0007	34.6703	34.6695	+0.0008
K24021	34.6323	34.6313	+0.0010	34.6690	34.6679	+0.0011
K24031	34.6333	34.6324	+0.0009	34.6692	34.6684	+0.0008
K24041	34.6336	34.6325	+0.0011	34.6704	34.6693	+0.0011
K24061	34.6359	34.6347	+0.0012	34.6692	34.6679	+0.0013
K24071	34.6298	34.6286	+0.0012	---	---	---
K24081	34.6369	34.6361	+0.0008	---	---	---
K24112	34.6340	34.6328	+0.0012	34.6706	34.6695	+0.0011
K24122	34.6296	34.6283	+0.0013	34.6687	34.6675	+0.0012
K24162	34.6320	34.6324	-0.0004	34.6702	34.6709	-0.0007
K24172	34.6293	34.6291	+0.0002	34.6698	34.6699	-0.0001
K24192	34.6366	34.6368	-0.0002	34.6715	34.6716	-0.0001
K24122	34.6354	34.6355	-0.0001	34.6722	34.6724	-0.0002
K1S022	34.6335	34.6334	+0.0001	34.6740	34.6739	+0.0001
K1S042	34.6325	34.6328	-0.0003	34.6708	34.6710	-0.0002
K1S062	34.6300	34.6302	-0.0002	34.6719	34.6719	+0.0000
K1S082	34.6333	34.6335	-0.0002	34.6695	34.6697	-0.0002
K1S092	34.6290	34.6292	-0.0002	34.6694	34.6696	-0.0002
K1S112	34.6262	34.6262	+0.0000	34.6703	34.6704	-0.0001
K1S122	34.6290	34.6292	-0.0002	34.6707	34.6708	-0.0001
K1S132	34.6325	34.6326	-0.0001	34.6684	34.6686	-0.0002
K1S152	34.6351	34.6351	+0.0000	34.6694	34.6695	-0.0001
K1S172	34.6295	34.6294	+0.0001	34.6673	34.6675	-0.0002
K1S182	34.6254	34.6253	+0.0001	34.6671	34.6671	+0.0000

Table 21-3 CTD Salinity from primary sensors at nominal bottle depths.

CTD salinity has been corrected for predicted temperature sensor drift

Cast#	Pressure (dbar)				
	5000	4750	4500	4250	4000
K6N021	---	---	---	---	34.6766
K6N041	---	---	---	---	34.6773
K6N051	---	34.6771	34.6771	34.6770	34.6767
K6N061	34.6770	34.6771	34.6771	34.6770	34.6767
K6N071	34.6771	34.6772	34.6771	34.6769	34.6767
K6N081	34.6771	34.6774	34.6771	34.6770	34.6765
K6N091**	34.6773	34.6773	34.6773	34.6771	34.6768
K6N101	34.6773	34.6772	34.6771	34.6770	34.6766
K6N111	34.6771	34.6773	34.6771	34.6771	34.6766
K6N121	---	---	34.6772	34.6771	34.6767
K6N131	34.6768	34.6766	34.6767	34.6766	34.6759
K6N141	34.6764	34.6765	34.6765	34.6763	34.6761
K24011	34.6764	34.6764	34.6763	34.6762	34.6760
K24021	34.6764	34.6765	34.6765	34.6762	34.6759
K24031	34.6764	34.6764	34.6762	34.6761	34.6759
K24041	---	---	---	---	34.6761
K24151	---	---	---	34.6768(1)	34.6767
K24192	---	34.6766	34.6765	34.6764	34.6760
K24202	---	---	---	34.6766	34.6764
K1S042	---	---	---	---	34.6757
K1S062	---	---	34.6763(2)	34.6760	34.6756
K1S082	---	---	---	---	34.6761
K1S112	---	---	34.6761	34.6760	34.6757
K1S122	---	34.6763	34.6762	34.6762	34.6760
K1S132	---	34.6760	34.6759	34.6758	34.6758
K1S152	34.6759	34.6759	34.6757	34.6759	34.6756
K1S162	34.6754	34.6754	34.6754	34.6752	34.6749
K1S172**	34.6756	34.6756	34.6754	34.6755	34.6749
K1S182	34.6757	34.6757	34.6756	34.6753	34.6752

(1) The pressure at this salinity sample was 4212 dbar.

(2) The pressure at this salinity sample was 4452 dbar.

\*\* These two stations were at the same location, 6 degN, 130 degE

Table 21-4 Difference between CTD salinity and Autosal Salinity at selected depths.

Difference = CTD - Autosal

CTD salinities have been corrected for predicted temperature sensor drift

Cast#	Pressure (dbar)				
	5000	4750	4500	4250	4000
K6N021	---	---	---	---	-0.0019
K6N041	---	---	---	---	-0.0014
K6N051	---	-0.0004	+0.0000	-0.0017	-0.0020
K6N061	-0.0015	-0.0010	-0.0010	-0.0011	-0.0010
K6N071	-0.0027	-0.0024	-0.0020	-0.0024	-0.0026
K6N081	-0.0029	-0.0026	-0.0027	---	-0.0033
K6N091	-0.0018	-0.0025	-0.0025	-0.0018	-0.0019
K6N101	-0.0020	+0.0001	-0.0018	-0.0023	-0.0005
K6N111	-0.0023	-0.0020	-0.0020	-0.0025	-0.0030
K6N121	---	---	-0.0024	-0.0022	-0.0026
K6N131	-0.0032	-0.0032	-0.0020	-0.0027	-0.0026
K6N141	-0.0021	-0.0031	-0.0022	-0.0022	-0.0016
K24011	-0.0030	-0.0001	-0.0026	-0.0027	-0.0029
K24021	-0.0027	-0.0022	-0.0028	-0.0036	-0.0012
K24031	-0.0027	-0.0023	-0.0015	-0.0024	-0.0020
K24041	---	---	---	---	-0.0023
K24151	---	---	---	-0.0023(1)	-0.0024
K24192	---	-0.0023	-0.0022	---	-0.0025
K24202	---	---	---	-0.0023	-0.0023
K1S042	---	---	---	---	-0.0034
K1S062	---	---	-0.0030(2)	-0.0033	-0.0027
K1S082	---	---	---	---	-0.0037
K1S112	---	---	-0.0037	-0.0029	-0.0034
K1S122	---	-0.0041	-0.0038	-0.0042	-0.0046
K1S132	---	-0.0048	-0.0041	-0.0027	-0.0027
K1S152	-0.0043	-0.0043	-0.0045	-0.0041	-0.0040

(1) The pressure of this salinity sample was actually 4212 dbar.

(2) The pressure at this salinity sample was 4452 dbar.

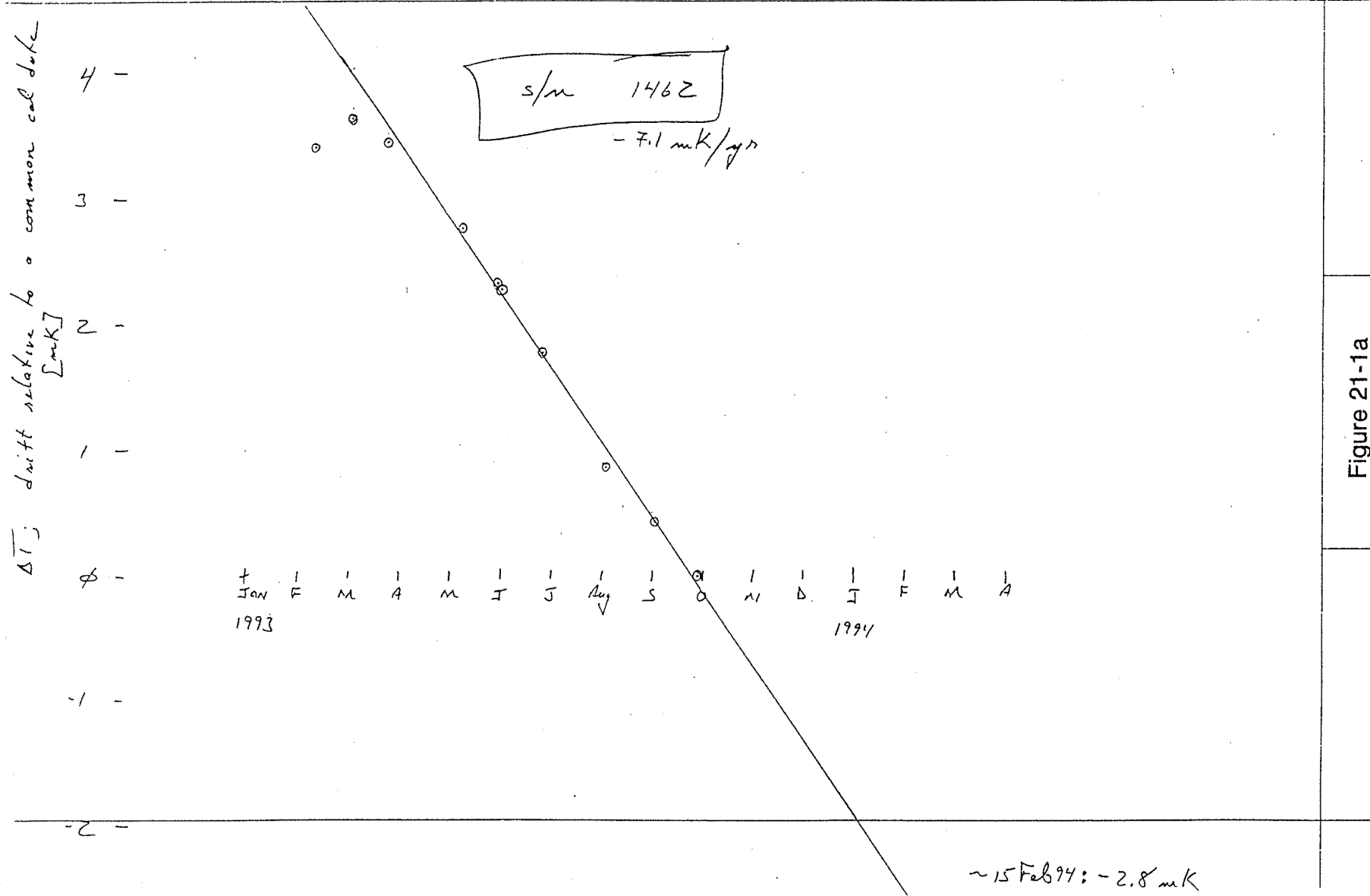

Figure 21-1a

SEA-BIRD ELECTRONICS, INC.  
 1808 136th Place N.E., Bellevue, Washington 98005  
 Telephone: (206) 643-9866 Telex: 292915 SBEI UR

TEMPERATURE CALIBRATION DATA  
 CALIBRATION DATE: 28-Sep-93s

SENSOR SERIAL NUMBER = 1462

a = 3.68127711e-03      b = 6.01141328e-04  
 c = 1.50672743e-05      d = 2.22741537e-06  
 $f_o = 6255.022$

BATH TEMP (°C)	INSTRUMENT FREQ (Hz)	INST TEMP (°C)	RESIDUAL (°C)
-1.50510	6255.022	-1.50514	-0.00004
1.00304	6615.993	1.00310	0.00006
4.48993	7142.402	4.48996	0.00003
8.08616	7716.040	8.08613	-0.00003
11.51150	8292.198	11.51146	-0.00004
15.06750	8921.831	15.06748	-0.00002
18.56712	9573.539	18.56715	0.00003
22.06048	10256.478	22.06052	0.00004
25.62000	10986.330	25.62000	-0.00000
29.02656	11717.567	29.02654	-0.00002
32.55856	12510.168	32.55857	0.00001

Temperature =  $1 / \{ a + b[Mn(f_o/f)] + c[Mn2(f_o/f)] + d[Mn3(f_o/f)] \} - 273.15$  (°C)

Residual = instrument temperature - bath temperature + 0.0000

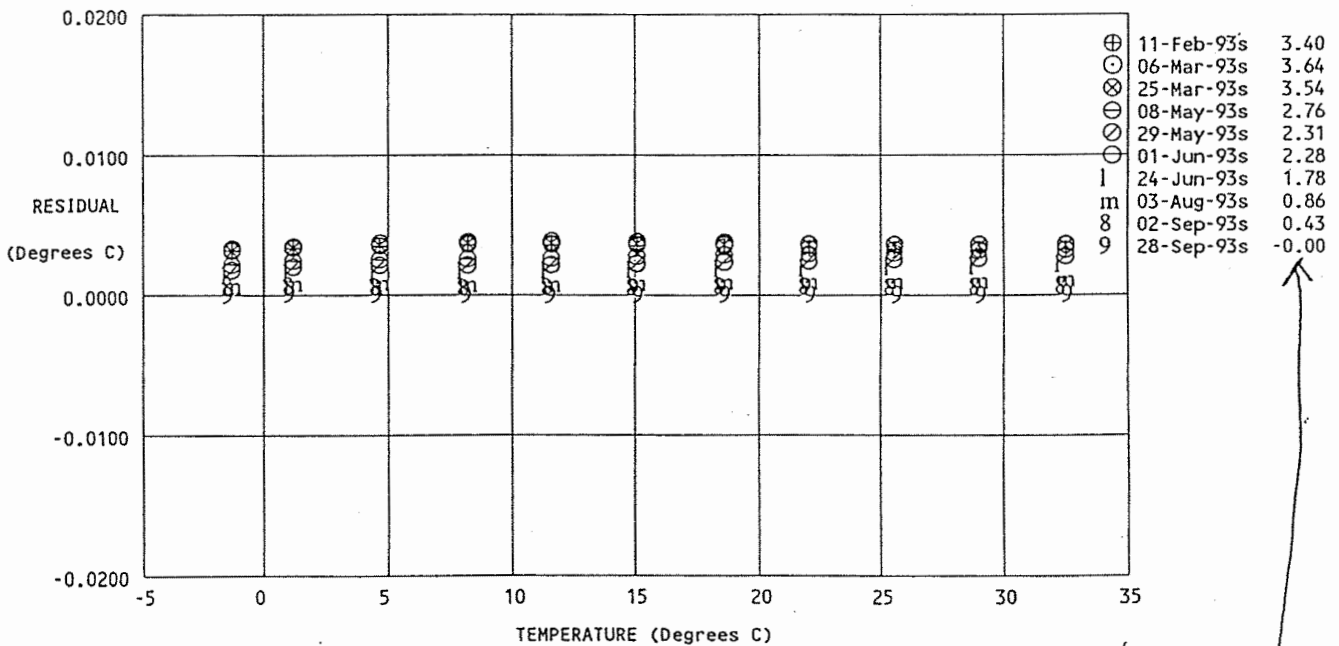

*drift in m°C relative to the calibration date at the top of this page.*  
**Figure 21-1b**

$\Delta T_j$  drift relative to a common cal date  
[mK]

4 -  
3 -  
2 -  
1 -  
0 -  
-1 -  
-2 -

J F M A M J J Aug S O N D Jan F M A  
1993 1994

s/n 1465

if (season - VI)  
and (Tsec - Tpri)

-7.2 mK/yr.

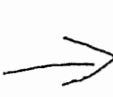

show  $\Delta T \sim \phi$  mK in deep ocean  
then s/n 1465 is drifting like s/n 1462  
and both are likely to be  $\sim -7.1$  mK/yr

-5.4 mK/yr

-15 Feb 94: -2.1 mK

Figure 21-2a

SEA-BIRD ELECTRONICS, INC.  
 1808 136th Place N.E., Bellevue, Washington 98005  
 Telephone: (206) 643-9866 Telex: 292915 SBEI UR

TEMPERATURE CALIBRATION DATA  
 CALIBRATION DATE: 28-Sep-93s

SENSOR SERIAL NUMBER = 1465

a = 3.68127719e-03      b = 6.00919785e-04  
 c = 1.52279882e-05      d = 2.32405040e-06  
 f<sub>0</sub> = 6339.674

BATH TEMP (°C)	INSTRUMENT FREQ (Hz)	INST TEMP (°C)	RESIDUAL (°C)
-1.50510	6339.674	-1.50515	-0.00005
1.00304	6705.676	1.00310	0.00006
4.48993	7239.454	4.48997	0.00004
8.08616	7821.159	8.08613	-0.00003
11.51150	8405.455	11.51145	-0.00005
15.06750	9044.022	15.06747	-0.00003
18.56712	9705.013	18.56715	0.00003
22.06048	10397.712	22.06052	0.00004
25.62000	11138.028	25.62000	0.00000
29.02656	11879.777	29.02655	-0.00001
32.55856	12683.792	32.55856	-0.00000

Temperature = 1/{a + b[Mn(f<sub>0</sub>/f)] + c[Mn2(f<sub>0</sub>/f)] + d[Mn3(f<sub>0</sub>/f)]} - 273.15 (°C)

Residual = instrument temperature - bath temperature + 0.0000

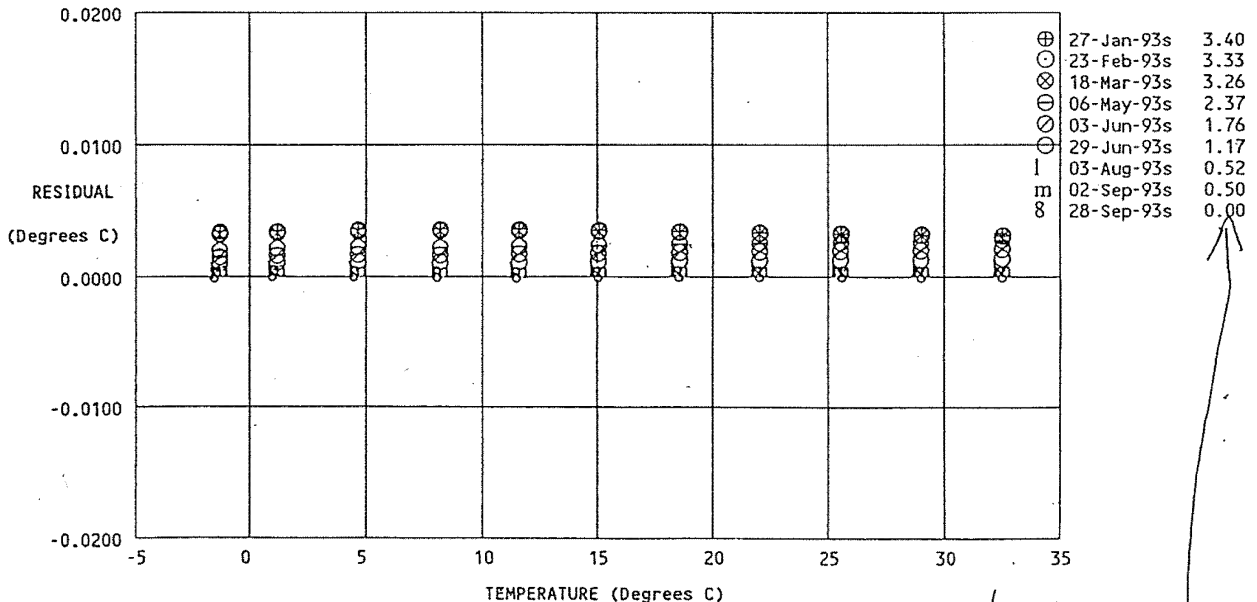

*draft in m°C relative to the calibration date at the top of this form.*

Figure 21-2b

CTD Salinity from .BTL file.

• CTD PRIMARY SENSORS  
(10 SECOND AVERAGES)

+ Autosat.

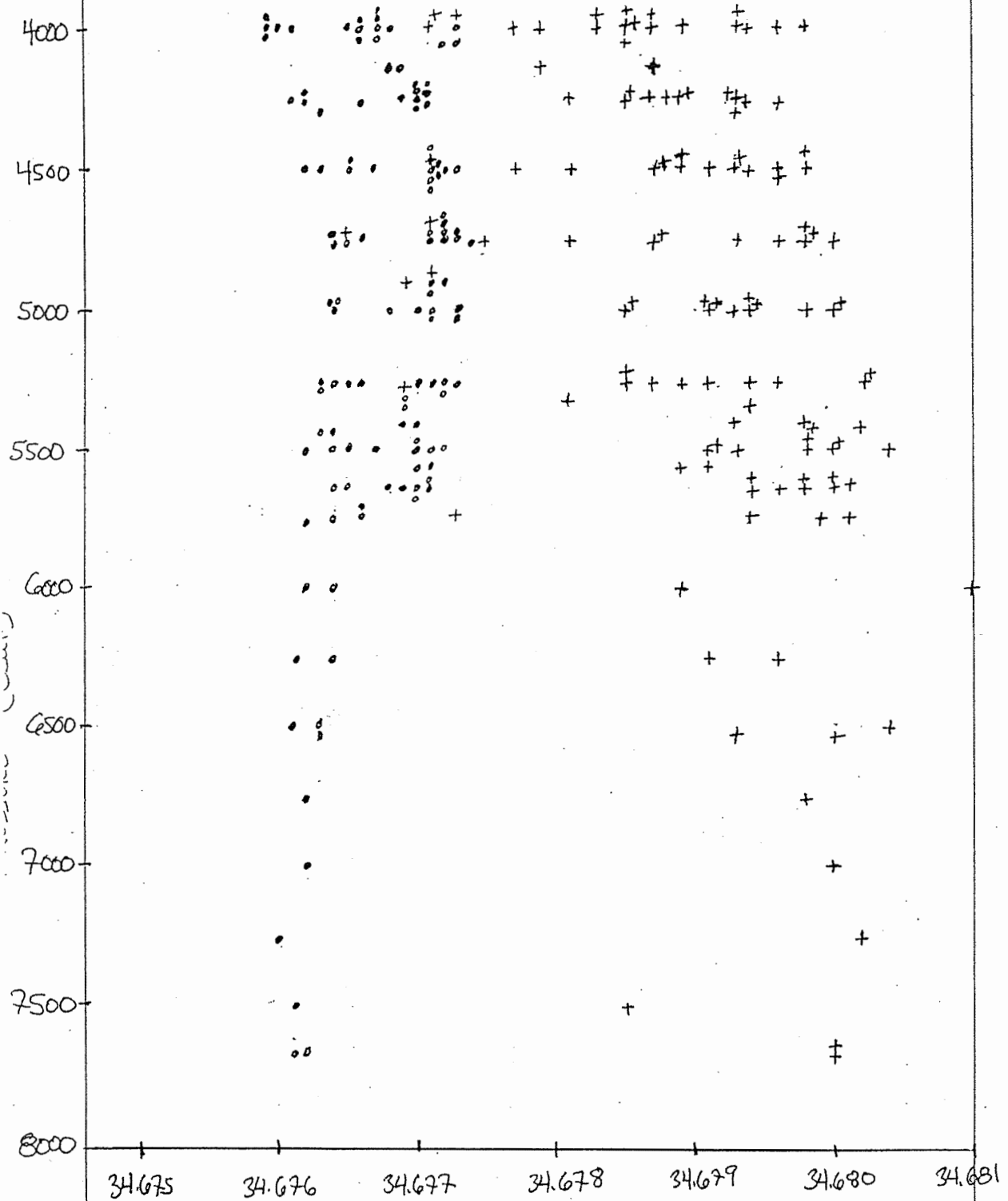

SALINITY

Figure 21-3

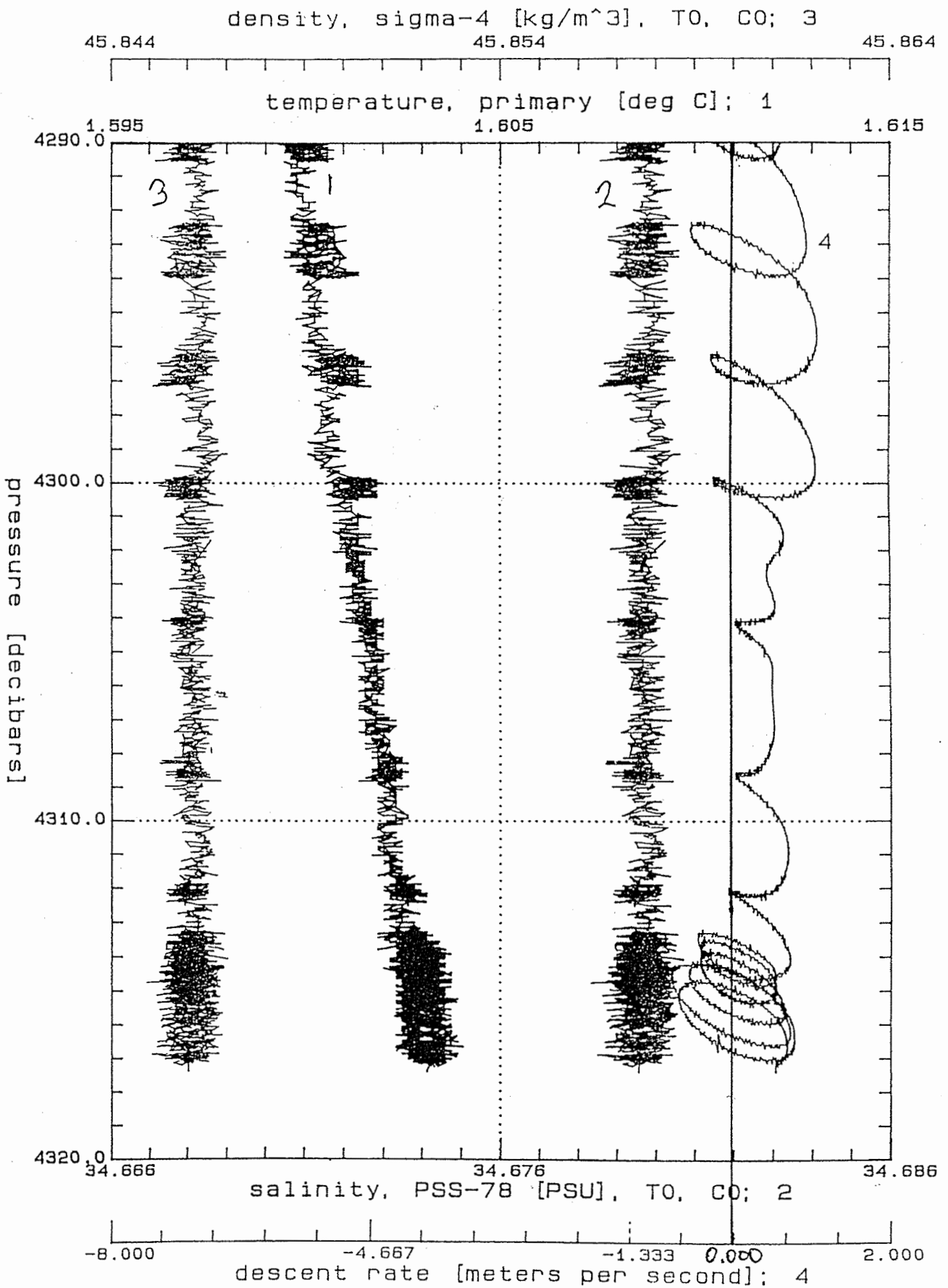

Figure 21-4

CAST K24201

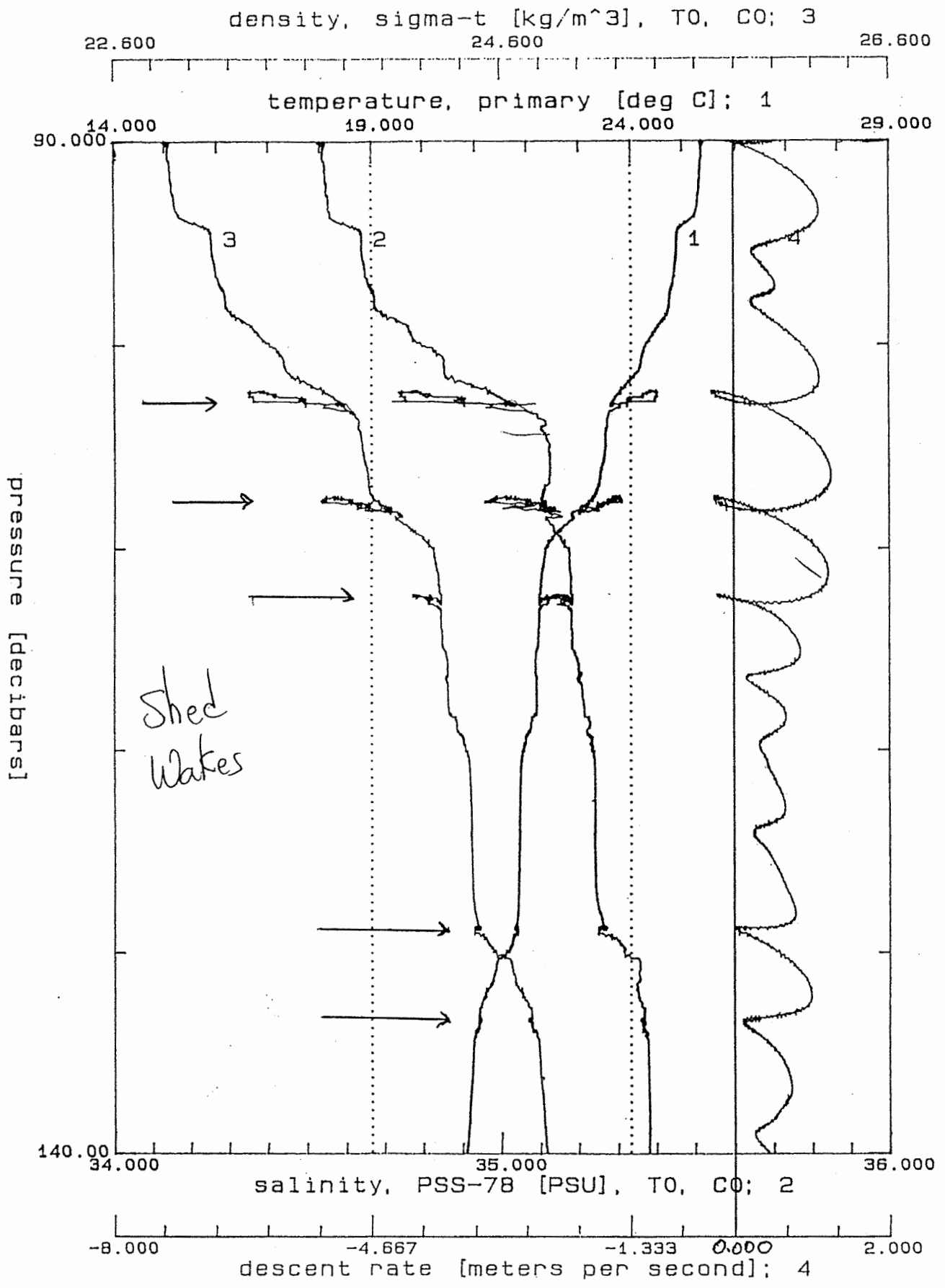

Figure 21-5 CAST K24201

# Acknowledgements

by M. Aoyama (10 March 1994)

The cruise participants thanks "very very much" to the captain H. Tanaka of R/V Kaiyo and the 26 crew for their powerfull and heartfull supports during the cruise. The deck crew for the CTD/Rosette operation could handle the big Rosette ( of 2.2 meters diameter, 1.8 meters height and almost 1000 Kg weights ) safely whenever the weather/sea condition becomes hard. The engineers/oilers also could operate the CTD winch well. The engineers and the oilers made many parts/materials to refine/ repair the instruments/machines for the observations. The boatswain and abledemans made the fine shellter for the meteorological observations for WOCE cruise. During the mooring, many of the crew supported the deck work and they often gave us the good comments/suggestions for the preparation of mooring. The radio operators and the cooks supported our living in the ship heartfully.

During the pre-cruise stage, three analist groups of salinity, dissolved oxygen and nutrients were largry supported by Mr. M . Mitsuya and Ms. H. Hamabe, the two staffs of the ocean-chemistry laborotory at Ocean Reseach Department, JAMSTEC. The director T. Nakanishi at the Ocean Research Department , JAMSTEC and the members at the Planning Department did the good arrangements to execute this cruise in the view point of the fund and on-shore laboratory space. Mr. I. Asanuma, the chief scientist at LIDAR cruise carried out just before this cruise, helped us much for the good on deck arrangments of the container laboratories, wiches and railway of the Rosette operation.

This cruise have executed on the basis of the collaborative ocean research framework between Japan Marine Science and Technology Center (JAMSTEC) and Badan Pengajian Dan Penerapan Teknologi (BPPT) since 1992.

This cruise is funded by the Japan-WOCE program with the Science and Technology Agency of Japan under the special coordinated funds and largery by some of the projects of JAMSTEC.